



TM8000 mobiles

TM8100 Mobile Radio
Service Manual



Contact Information

Tait Radio Communications

<http://www.taitworld.com>

Corporate Head Office New Zealand

Tait Electronics Ltd
P.O. Box 1645
Christchurch
New Zealand
E-mail: info@taitworld.com
Website: <http://www.taitworld.com>

Technical Support:
E-mail: support@taitworld.com
Website: <http://support.taitworld.com>

Tait North America

Regional Head Office: United States of America
Tait North America Inc
E-mail: usa@taitworld.com

Canada
Tait North America Inc
E-mail: canada@taitworld.com

Latin America

Tait Latin America
E-mail: latinamerica@taitworld.com

Tait Europe

Regional Head Office: United Kingdom
Tait Mobile Radio Ltd
E-mail: teusales@tait.co.uk

Tait North Asia

Regional Head Office: Hong Kong
Tait Mobile Radio (Hong Kong) Ltd
E-mail: hongkong@taitworld.com

Beijing
Tait Mobile Radio (Hong Kong) Ltd
E-mail: beijing@taitworld.com

Tait South Asia

Regional Head Office: Singapore
Tait Electronics (Far East) Pte Ltd
E-mail: singapore@taitworld.com

Thailand
Tait Mobile Radio Ltd
E-mail: thailand@taitworld.com

Tait Oceania

New Zealand
Tait Communications Ltd
E-mail: headoffice@tcl.tait.co.nz

Australia
Tait Electronics (Aust) Pty Ltd
E-mail: australia@taitworld.com

Note

For the addresses and telephone numbers of the above regional offices refer to the TaitWorld website.

Tait General Software Licence Agreement

This legal document is an Agreement between you (the "Licensee") and Tait Electronics Limited ("Tait"). By using any of the Software or Firmware items prior-installed in the related Tait product, included on this CD or downloaded from the Tait website, (hereinafter referred to as "the Software or Firmware") you agree to be bound by the terms of this Agreement. If you do not agree to the terms of this Agreement, do not install and use any of the Software or Firmware. If you install and use any of the Software or Firmware that will be deemed to be acceptance of the terms of this licence agreement.

The terms of this agreement shall apply subject only to any express written terms of agreement to the contrary between Tait and the Licensee.

Licence

TAIT GRANTS TO YOU AS LICENSEE THE NON-EXCLUSIVE RIGHT TO USE THE SOFTWARE OR FIRMWARE ON A SINGLE MACHINE PROVIDED YOU MAY ONLY:

1. COPY THE SOFTWARE OR FIRMWARE INTO ANY MACHINE READABLE OR PRINTED FORM FOR BACKUP PURPOSES IN SUPPORT OF YOUR USE OF THE PROGRAM ON THE SINGLE MACHINE (CERTAIN PROGRAMS, HOWEVER, MAY INCLUDE MECHANISMS TO LIMIT OR INHIBIT COPYING, THEY ARE MARKED "COPY PROTECTED"), PROVIDED THE COPYRIGHT NOTICE MUST BE REPRODUCED AND INCLUDED ON ANY SUCH COPY OF THE SOFTWARE OR FIRMWARE; AND / OR
2. MERGE IT INTO ANOTHER PROGRAM FOR YOUR USE ON THE SINGLE MACHINE (ANY PORTION OF ANY SOFTWARE OR FIRMWARE MERGED INTO ANOTHER PROGRAM WILL CONTINUE TO BE SUBJECT TO THE TERMS AND CONDITIONS OF THIS AGREEMENT).

THE LICENSEE MAY NOT DUPLICATE, MODIFY, REVERSE COMPILE OR REVERSE ASSEMBLE ANY SOFTWARE OR FIRMWARE IN WHOLE OR PART.

Title to Software

THIS AGREEMENT DOES NOT CONSTITUTE A CONTRACT OF SALE IN RELATION TO THE SOFTWARE OR FIRMWARE SUPPLIED TO THE LICENSEE. NOT WITHSTANDING THE LICENSEE MAY OWN THE MAGNETIC OR OTHER PHYSICAL MEDIA ON WHICH THE SOFTWARE OR FIRMWARE WAS ORIGINALLY SUPPLIED, OR HAS SUBSEQUENTLY BEEN RECORDED OR FIXED, IT IS A FUNDAMENTAL TERM OF THIS AGREEMENT THAT AT ALL TIMES TITLE AND OWNERSHIP OF THE SOFTWARE OR FIRMWARE, WHETHER ON THE ORIGINAL MEDIA OR OTHERWISE, SHALL REMAIN VESTED IN TAIT OR THIRD PARTIES WHO HAVE GRANTED LICENCES TO TAIT.

Term and Termination

THIS LICENCE SHALL BE EFFECTIVE UNTIL TERMINATED IN ACCORDANCE WITH THE PROVISIONS OF THIS AGREEMENT. THE LICENSEE MAY TERMINATE THIS LICENCE AT ANY TIME BY DESTROYING ALL COPIES OF THE SOFTWARE OR FIRMWARE AND ASSOCIATED WRITTEN MATERIALS. THIS LICENCE WILL BE TERMINATED AUTOMATICALLY AND WITHOUT NOTICE FROM TAIT IN THE EVENT THAT THE LICENSEE FAILS TO COMPLY WITH ANY TERM OR CONDITION OF THIS AGREEMENT. THE LICENSEE AGREES TO DESTROY ALL COPIES OF THE SOFTWARE OR FIRMWARE AND ASSOCIATED WRITTEN MATERIALS IN THE EVENT OF SUCH TERMINATION.

Limited Warranty

THE SOFTWARE OR FIRMWARE IS SUPPLIED BY TAIT AND ACCEPTED BY THE LICENSEE "AS IS" WITHOUT WARRANTY OF ANY KIND EITHER EXPRESSED OR IMPLIED, INCLUDING BUT NOT BEING LIMITED TO ANY IMPLIED WARRANTIES AS TO MERCHANTABILITY OR FITNESS FOR ANY PARTICULAR PURPOSE. THE LICENSEE ACKNOWLEDGES THAT THE SOFTWARE OR FIRMWARE IS USED BY IT IN BUSINESS AND ACCORDINGLY TO THE MAXIMUM EXTENT PERMITTED BY LAW NO TERMS OR WARRANTIES WHICH ARE IMPLIED BY LEGISLATION SHALL APPLY TO THIS AGREEMENT. TAIT DOES NOT WARRANT THAT THE FUNCTIONS CONTAINED IN THE SOFTWARE OR FIRMWARE WILL MEET THE LICENSEE'S REQUIREMENTS OR THAT THE OPERATION OF THE SOFTWARE OR FIRMWARE WILL BE UNINTERRUPTED OR ERROR-FREE.

Exclusion of Liability

TAIT'S ENTIRE LIABILITY AND THE LICENSEE'S EXCLUSIVE REMEDY SHALL BE THE FOLLOWING:

1. IN NO CIRCUMSTANCES SHALL TAIT BE UNDER ANY LIABILITY TO THE LICENSEE, OR ANY OTHER PERSON WHATSOEVER, FOR ANY DIRECT OR CONSEQUENTIAL DAMAGE ARISING OUT OF OR IN CONNECTION WITH ANY USE OR INABILITY OF USING THE SOFTWARE OR FIRMWARE.
2. TAIT WARRANTS THE OPERATION OF THE SOFTWARE OR FIRMWARE ONLY WITH THE OPERATING SYSTEM FOR WHICH IT WAS DESIGNED. USE OF THE SOFTWARE OR FIRMWARE WITH AN OPERATING SYSTEM OTHER THAN THAT FOR WHICH IT WAS DESIGNED MAY NOT BE SUPPORTED BY TAIT, UNLESS OTHERWISE EXPRESSLY AGREED BY TAIT.

General

THE LICENSEE CONFIRMS THAT IT SHALL COMPLY WITH THE PROVISIONS OF LAW IN RELATION TO THE SOFTWARE OR FIRMWARE.

Law and Jurisdiction

THIS AGREEMENT SHALL BE SUBJECT TO AND CONSTRUED IN ACCORDANCE WITH NEW ZEALAND LAW AND DISPUTES BETWEEN THE PARTIES CONCERNING THE PROVISIONS HEREOF SHALL BE DETERMINED BY THE NEW ZEALAND COURTS OF LAW. PROVIDED HOWEVER TAIT MAY AT ITS ELECTION BRING PROCEEDINGS FOR BREACH OF THE TERMS HEREOF OR FOR THE ENFORCEMENT OF ANY JUDGEMENT IN RELATION TO A BREACH OF THE TERMS HEREOF IN ANY JURISDICTION TAIT CONSIDERS FIT FOR THE PURPOSE OF ENSURING COMPLIANCE WITH THE TERMS HEREOF OR OBTAINING RELIEF FOR BREACH OF THE TERMS HEREOF.

No Dealings

THE LICENSEE MAY NOT SUBLICENSE, ASSIGN OR TRANSFER THE LICENCE OR THE PROGRAM EXCEPT AS EXPRESSLY PROVIDED IN THIS AGREEMENT. ANY ATTEMPT OTHERWISE TO SUBLICENSE, ASSIGN OR TRANSFER ANY OF THE RIGHTS, DUTIES OR OBLIGATIONS HEREUNDER IS VOID.

No Other Terms

THE LICENSEE ACKNOWLEDGES THAT IT HAS READ THIS AGREEMENT, UNDERSTANDS IT AND AGREES TO BE BOUND BY ITS TERMS AND CONDITIONS. THE LICENSEE FURTHER AGREES THAT SUBJECT ONLY TO ANY EXPRESS WRITTEN TERMS OF AGREEMENT TO THE CONTRARY BETWEEN TAIT AND THE LICENSEE THIS IS THE COMPLETE AND EXCLUSIVE STATEMENT OF THE AGREEMENT BETWEEN IT AND TAIT IN RELATION TO THE SOFTWARE OR FIRMWARE WHICH SUPERSEDES ANY PROPOSAL OR PRIOR AGREEMENT, ORAL OR WRITTEN AND ANY OTHER COMMUNICATIONS BETWEEN THE LICENSEE AND TAIT RELATING TO THE SOFTWARE OR FIRMWARE.

Contents

Preface	6
Notes for Readers	7
Typographical Conventions	8
Associated Documents	9
Amendment Record	10
List of Acronyms	11
1 Introduction	13
1.1 TM8100 Mobile Radio System	13
1.2 Radio Body	19
1.3 Control Head	21
1.4 Repair Levels	22
1.5 Product Codes	23
2 General Description	27
2.1 Architecture of Radio	27
2.2 Operation of Control-head Circuitry	29
2.3 Operation in Receive Mode	31
2.4 Operation in Transmit Mode	34
2.5 Operation of Frequency Synthesizer	37
3 Disassembly and Re-assembly of Radio	39
3.1 Detachment of Control Head	41
3.2 Disassembly of Control Head	45
3.3 Disassembly of Radio Body	51
3.4 Re-assembly of Radio Body	58
3.5 Re-assembly and Attachment of Control Head	61

Preface

Scope of service manual

This manual provides information to service technicians for carrying out level-1 repairs of TM8100 mobile radios. Level-1 repairs entail the replacement of faulty parts and circuit boards.

The manual does not cover level-2 repairs (repair of circuit boards, with the exception of certain special items on the boards) and level-3 repairs (repair of the special items).

The servicing procedures are moreover limited to the control head and radio body of TM8100 mobile radios. Servicing of all accessories associated with the radio is covered in the accessories manual.

Summary of service manual

The service manual is divided into three sections. The first section introduces the radio. The main products making up the radio system are identified (in particular, the control head and radio body), the repair levels are discussed, and the product codes of the control head and radio body are given.

In the second section the functioning of the radio is described. The description is limited to the control head and radio body. The architecture of the radio, the operation of the control-head circuitry, the functioning of the radio in the receive and transmit modes, and the operation of the frequency synthesizer are described.

The third section provides information regarding the level-1 repair procedures. The information is mainly limited to the procedures for disassembling and re-assembling the radio. Only a brief outline is given of the overall repair procedures themselves.

Notes for Readers

Enquiries and comments

Any enquiries regarding this manual or the equipment that it describes, as well as any comments, suggestions and notifications of errors, should be addressed by e-mail to Technical Support (support@taitworld.com) or to the Technical Support Manager, Tait Electronics Limited, PO Box 1645, Christchurch, New Zealand. Orders for this manual can be placed with your Tait Dealer.

Updates of manual and equipment

In the interests of improving the performance, reliability or servicing of the equipment, Tait Electronics Limited reserves the right to upgrade the equipment or update this manual or both without prior notice.

Copyright

All information contained in this manual is the property of Tait Electronics Limited. All rights are reserved. This manual may not, in whole or in part, be copied, photocopied, reproduced, translated, stored, or reduced to any electronic medium or machine-readable form, without prior written permission from Tait Electronics Limited. All trade names referenced are the service mark, trade mark, or registered trade mark of the respective manufacturers.

Disclaimer

There are no warranties extended or granted by this manual. Tait Electronics Limited accepts no responsibility for damage arising from use of the information contained in the manual or of the equipment and software it describes. It is the responsibility of the user to ensure that use of such information, equipment and software complies with the laws, rules and regulations of the applicable jurisdictions.

Typographical Conventions

Conventions and alerts

In this manual the names of electrical signals are typed in small capitals using the standard sans-serif font of the document. For example:

TX INHIBIT

Alert notices that appear in the manual are selected from whichever of the following are appropriate. These alert notices are in accordance with the ANSI definitions.



Warning!! This alert notice is used when there is a potential risk of death or serious injury.



Caution This alert notice is used when there is a risk of minor to moderate injury to people.



Important This alert notice is used to warn about the risk of equipment damage or malfunction.



Note This alert notice is used to highlight information that is required to ensure that procedures are performed correctly.

Associated Documents

Basic manuals

Together with this service manual, the following manuals are of concern to service technicians. The pair of digits in the third field of the document product code indicates the language of the document — 00 indicates an English and 03 a multi-lingual document.

MM8100-00-03-804

TM8100 mobile radio — User's guide

MMAA00-00-00-812

TM8100 mobile radio — Accessories manual

PCB information packages

Information on the circuit boards is supplied in the following separate documents. The information consists of the BOMs (parts lists), grid reference indexes, PCB layouts, and circuit diagrams.

MMAB12-H5-00-814

Main board (H5/H6) — PCB information package

MMAB12-B1-00-814

Main board (B1) — PCB information package

MMAC20-00-00-814

Control-head board — PCB information package

3DK manuals

The following manuals are mainly of concern to third-party developers. The manuals are supplied in soft-copy form on a 3DK resource CD.

MMAA30-00-00-807

TM8000 3DK hardware developer's kit — Application manual

MMAA30-02-00-429

TM8000 3DK application board — Software programmer's manual

MMAA30-02-00-812

TM8000 3DK application board — Service manual

MM8100-00-00-441

TM8100 Computer-controlled data interface — Protocol definition

Amendment Record

Version	Publication date	Amended sections and pages
1.00	September 2003	First release

List of Acronyms

3DK	Third-party Developer's Kit
AC	Alternating Current
ACP	Adjacent Channel Power
ADC	Analogue-to-digital Converter
AGC	Automatic Gain Control
ALC	Automatic Level Control
ASC	Accredited Service Centre
BOM	Bill of Materials
CODEC	Coder-decoder
CSO	Customer Service Organisation
DAC	Digital-to-analogue Converter
DC	Direct Current
DIN	Deutsche Industrie Norm
DSP	Digital Signal Processor
DTMF	Dual-tone Multi-frequency
FCL	Frequency Control Loop
FPGA	Field-programmable Gate Array
IPN	Internal Part Number
IC	Integrated Circuit
IF	Intermediate Frequency
IQ	In-phase and Quadrature
ISC	International Service Centre
LCD	Liquid-crystal Display
LED	Light-emitting Diode
LO	Local Oscillator
PA	Power Amplifier
PCB	Printed Circuit Board
PLL	Phase-locked Loop
RF	Radio Frequency
RSSI	Received Signal Strength Indication
SMT	Surface-mount Technology
TCXO	Temperature-compensated Crystal Oscillator
TEL	Tait Electronics Limited
UHF	Ultra-high Frequency
VCO	Voltage-controlled Oscillator
VCXO	Voltage-controlled Crystal Oscillator
VHF	Very High Frequency

1 Introduction

Scope of section

This section introduces the TM8100 mobile radio system. The main items making up the system are first introduced. There follows additional information on the radio body and control head — the two items that are the prime concern of the service manual. Next is a discussion of the repair levels that govern the servicing of the radio body and control head. The section concludes with an explanation of the product codes for these items.

1.1 TM8100 Mobile Radio System

Main items of system

The TM8100 mobile radio system is a high-performance microprocessor-controlled transceiver with a comprehensive range of accessories. The system is designed primarily for installation in vehicles but can also be used in desktop, remote-monitoring and similar applications. The system consists of the following main items:

- radio body
- control head
- audio accessories
- mounting for radio
- desktop power supply (optional)

The service manual covers the servicing of the radio body and control head only. The accessories manual covers servicing of all the remaining items.

Specifications for system

The specifications for the system are not given in this manual, but will be found instead on the TaitWorld website in the area reserved for TM8000 products. This ensures that the latest specification data will always be available to service technicians.

Radio body

The radio body contains the transmitter, receiver and microprocessor circuitry. The radio body also allows for the fitting of an internal options board to provide additional functions. There are three standard external connectors on the radio body: an RF connector, power connector, and auxiliary connector. If an internal options board is fitted, there might or might not be an associated external options connector. The auxiliary and external options connectors allow for the connection of various external devices.



Figure 1.1 Illustrations of the TM8115 mobile radio showing both the front and rear



Figure 1.2 Illustration of the front of the TM8105 mobile radio

Control head

The control head is attached to the radio body. There is a choice of two control heads:

- two-digit-display control head
- blank control head

The two-digit display control head provides the interface with the radio user and includes a socket for the connection of a microphone. The blank control head has no user interface but has a single external connector called the programming connector; this is typically used for programming and monitoring purposes. The radio is designated TM8115 with the two-digit-display control head and TM8105 with the blank control head. Illustrations of these radios are given in Figure 1.1 and Figure 1.2.

Audio accessories

One or more audio accessories may be connected to the control head and radio body. A microphone is the accessory usually required; other accessories that are available are a handset, high-power remote speaker, and hands-free kit. Various external devices may also be connected. The user's guide and accessories manual describe the audio accessories.

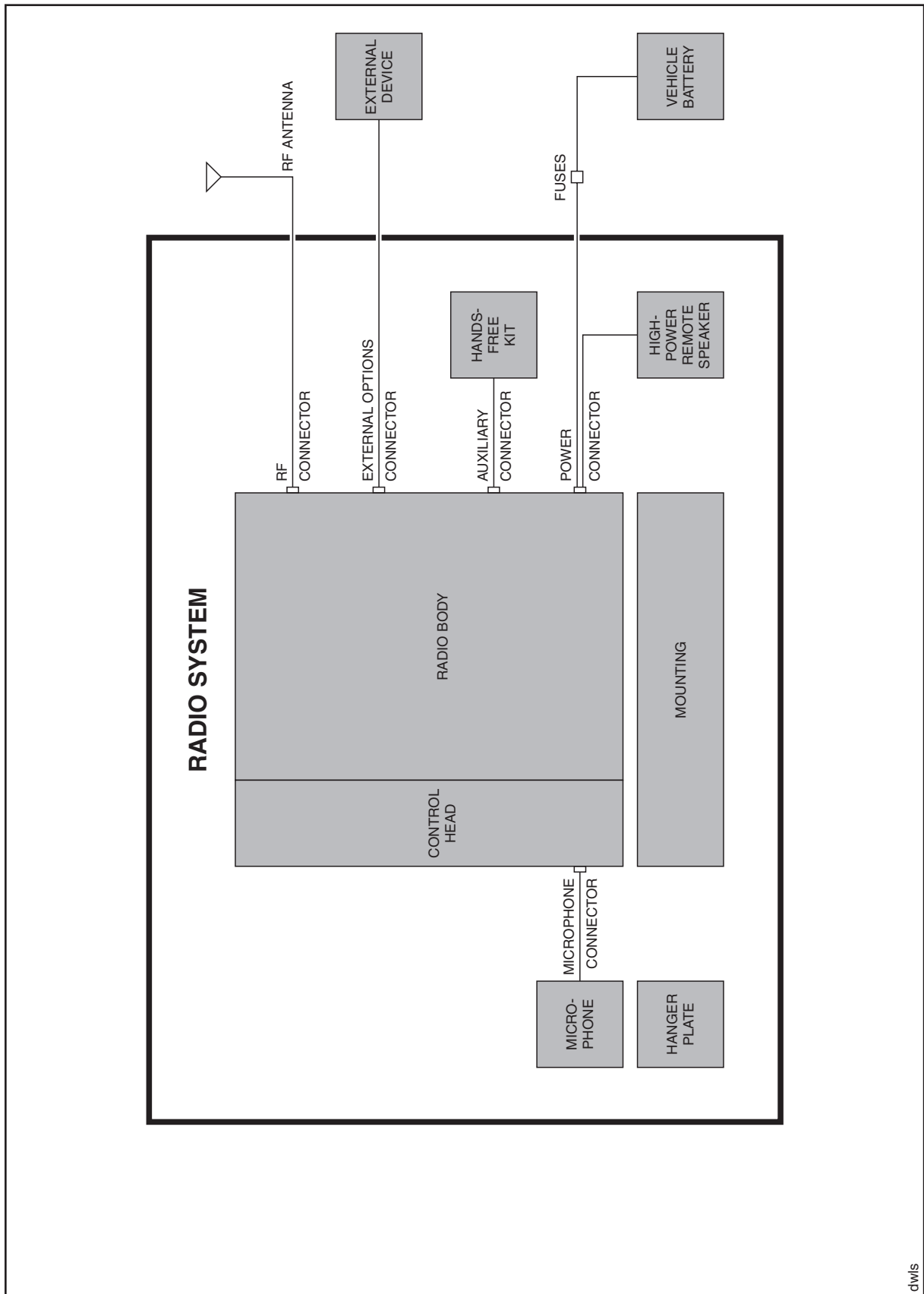

Figure 1.3 Block diagram of an example installation of the TM8115 mobile radio in a vehicle

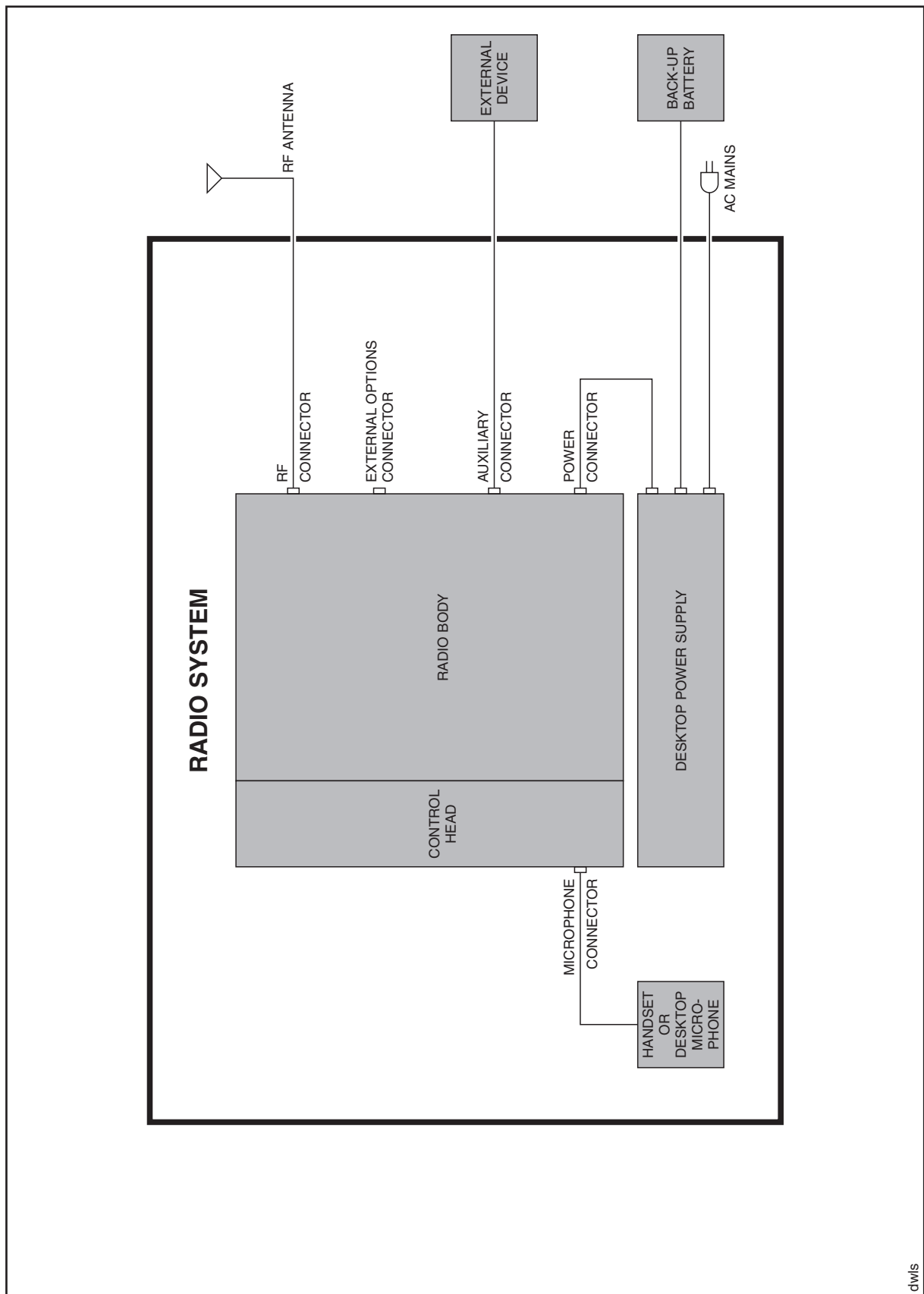

Figure 1.4 Block diagram of an example desktop installation of the TM8115 mobile radio

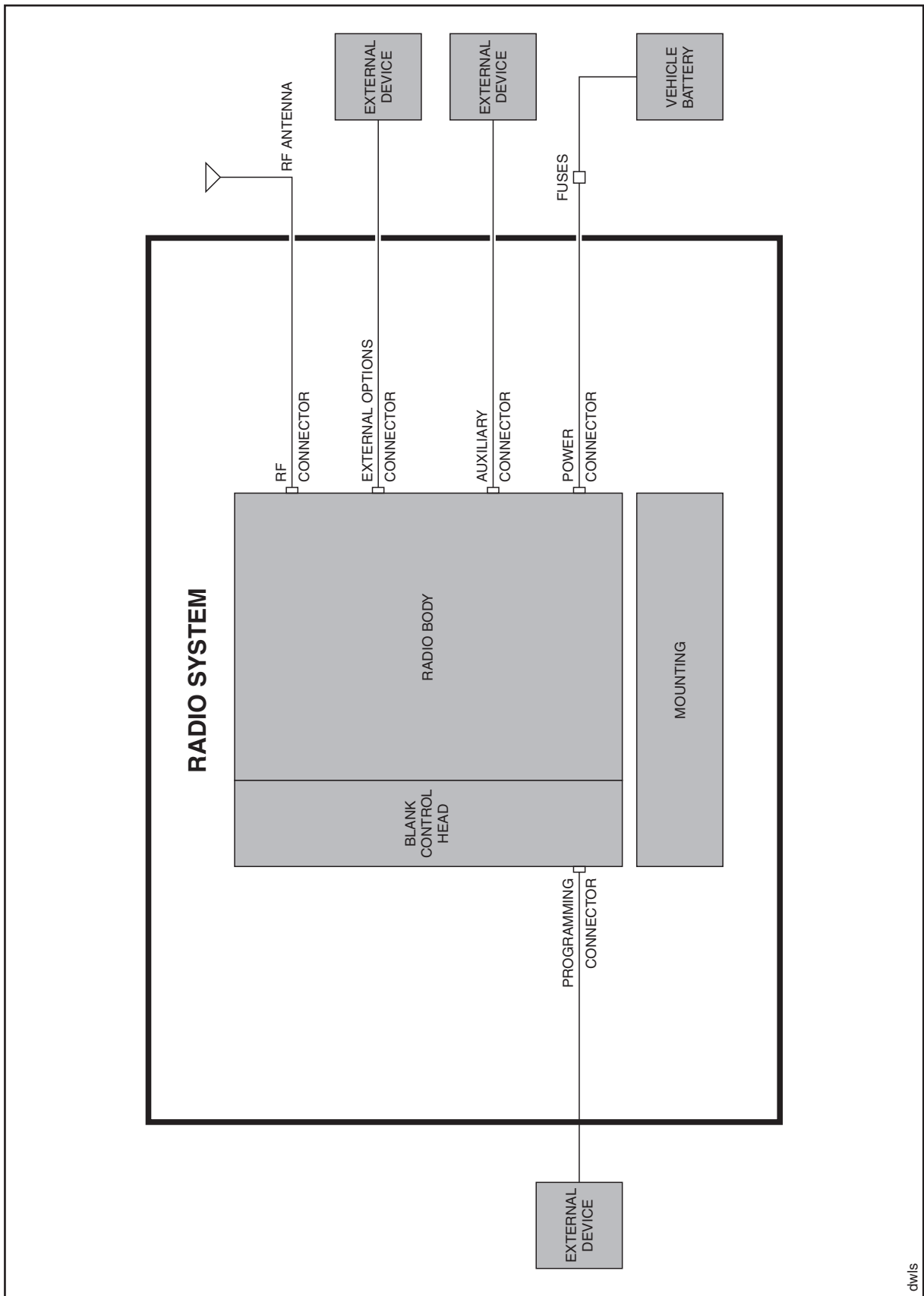

Figure 1.5 Block diagram of an example installation of the TM8105 mobile radio in a vehicle

Installation kits and desktop power supply

The mounting hardware for the radio is in the form of a U-cradle. It is supplied in an installation kit and provides for the installation of the radio in a vehicle. Alternatively, the radio might be needed for desktop use, in which case a desktop power supply is required. In some desktop installations the U-cradle is used to attach the radio to the power supply. The user's guide and accessories manual describe the installation kit.

Block diagrams of system

The block diagrams of Figure 1.3 to Figure 1.5 illustrate possible configurations of the radio system. Figure 1.3 and Figure 1.4 show example installations of the TM8115 radio (with two-digit-display control head) in a vehicle and on a desktop. Figure 1.5 shows an example of the TM8105 radio (with blank control head) installed in a vehicle. Different audio accessories are shown connected to the radio. The hands-free kit is connected to the auxiliary connector, and the remote speaker to the power connector. The accessories that may be connected to the microphone connector include the rugged microphone, as well as a DTMF microphone, desktop microphone, and handset.

1.2 Radio Body

Main, digital and internal options boards

The radio body consists of a rectangular case — or chassis — with a lid. The case houses a main board with the receiver and transmitter circuitry, and a digital board with the microprocessor that controls the radio. There are different main boards available covering different frequency bands and with different RF performances; refer to the product codes in Figure 1.8. The digital board is reflow-soldered to the main board. There is space in the lid for an optional internal options board. The essentials of the arrangement are illustrated in the block diagram of Figure 1.6.

Main-board assembly

The rear edge of the main board is attached to a heat-transfer block. The block is in thermal contact with the rear of the case, where there are cooling fins for heat dissipation. Heat from the output stage of the transmitter is conducted via the heat-transfer block to the rear and radiated from the cooling fins. (The lower surface of the case is ridged to augment the dissipation of heat.) The RF, auxiliary and power connectors are fixed to the rear of the main board. They project through apertures in the heat-transfer block and the rear of the case. The main board, digital board, and heat-transfer block constitute a separate unit called the main-board assembly.

Internal options boards

Either Tait-designed or custom internal options boards may be fitted in the radio body. Full details of the boards are given in the accessories and 3DK manuals. Any internal options board that is fitted might or might not include an external options connector. If included, the connector will project through an aperture in the rear of the lid. If there is no connector, the aperture is sealed with a bung.

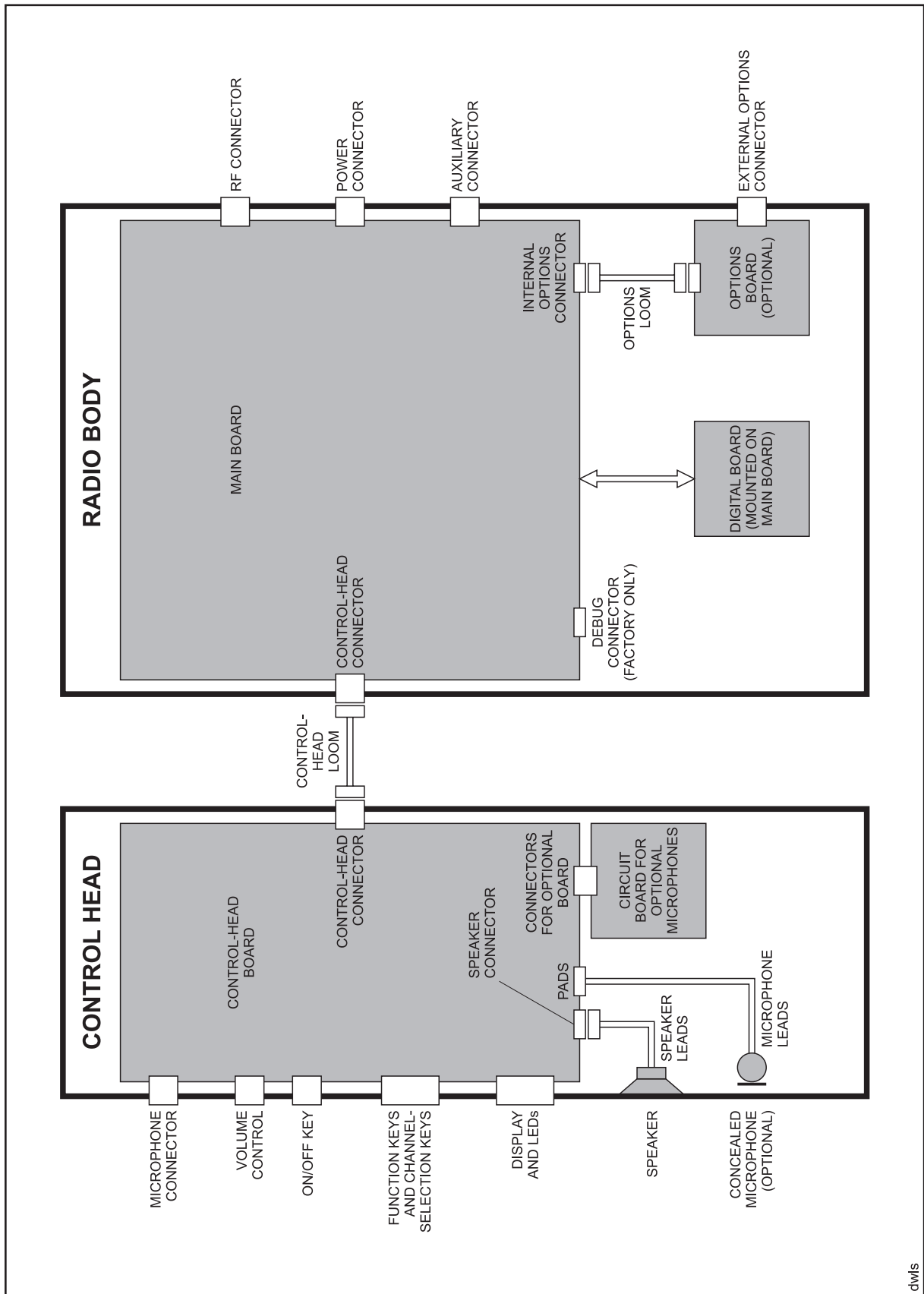

Figure 1.6 Block diagram of the radio body and control head of the TM8115 mobile radio

Internal connections

There are three sets of internal connections to the main board; these use the following connectors:

- debug connector
- control-head connector
- internal options connector

The debug connector is for Factory use only. The control-head connector is on the front edge of the main board; it is used to connect a control-head loom from the control head to the main board. The internal options connector is required when an internal options board is fitted; it is used to connect an options loom between the two boards.

1.3 Control Head

Introduction

The control head clips securely to the front of the radio body. The control-head loom between the two is enclosed in the space between them. For badging and branding purposes there are both a logo and a label for the product model code on the front panel. The control head may also be left unbadged. The essentials of the two-digit-display control head are shown in the block diagram of Figure 1.6.

Two-digit-display control head

The front panel of the two-digit-display control head is fitted with the controls and indicators needed by the radio user; these comprise:

- LCD screen
- indicator LEDs
- volume control
- on/off key
- function keys
- channel-selection keys

In addition, there are the microphone connector and an internal speaker. The necessary circuitry for the above items is mounted on a control-head board fitted behind the front panel. The volume-control potentiometer is fixed to the board; so is a control-head connector, which is used for the control-head loom between the control head and radio body.

Options for control head

The two-digit-display control head allows for an optional concealed microphone or the use of a dynamic microphone. (A concealed microphone is fitted behind the front panel next to the speaker.) With either option a separate circuit board is required for the microphone. This board is connected to the control-head board by means of two connectors; the plugs of the connectors are mounted on the latter board and the sockets on the former. Full details of the optional microphones and circuit board are given in the accessories manual.

Blank control head

The blank control head has none of the features of the two-digit-display control head. The front panel of the blank control head is fitted only with the single programming connector. The control-head loom is permanently fixed to the rear of the programming connector. The space inside the control head can be used for the fitting of an optional third-party circuit board, but is otherwise empty.

1.4 Repair Levels

Level-1 repairs

The repairs that can be carried out on the TM8100 mobile radio are grouped into categories — or levels — of increasing complexity. This manual covers only level-1 repairs, which comprise the following:

- replacement of control-head board
- replacement of main-board assembly
- replacement of other parts

The last-named parts include the connectors and volume-control potentiometer on the control-head board, but not the connectors on the main board.

Level-2 repairs

It is important to distinguish level-1 repairs from the higher-level repairs, which require greater skills and resources. Thus, level-2 repairs comprise the following:

- repair of control-head board
- repair of main-board assembly, excluding special items

These repairs entail the replacement of faulty SMT components on the boards, as well as the connectors on the main board. The special items are the digital board and certain components on the main board. (Repairs of the special items are level-3 repairs.)

Service centres

The service centres that carry out repairs of TM8100 mobile radios can be divided into three categories:

- Dealers and Customers with appropriate facilities
- ASCs, including CSOs
- TEL and ISC

ASCs, the ISC and TEL may carry out both level-1 and level-2 repairs. These are moreover the only service centres that may repair a radio that is still under warranty — any repair by a non-accredited service centre will void the warranty. After the expiry of the warranty, Dealers and Customers with appropriate facilities may also carry out level-1 repairs, but are strongly advised not to attempt level-2 repairs. Contact Technical Support for details of the process by which service centres may achieve accreditation.

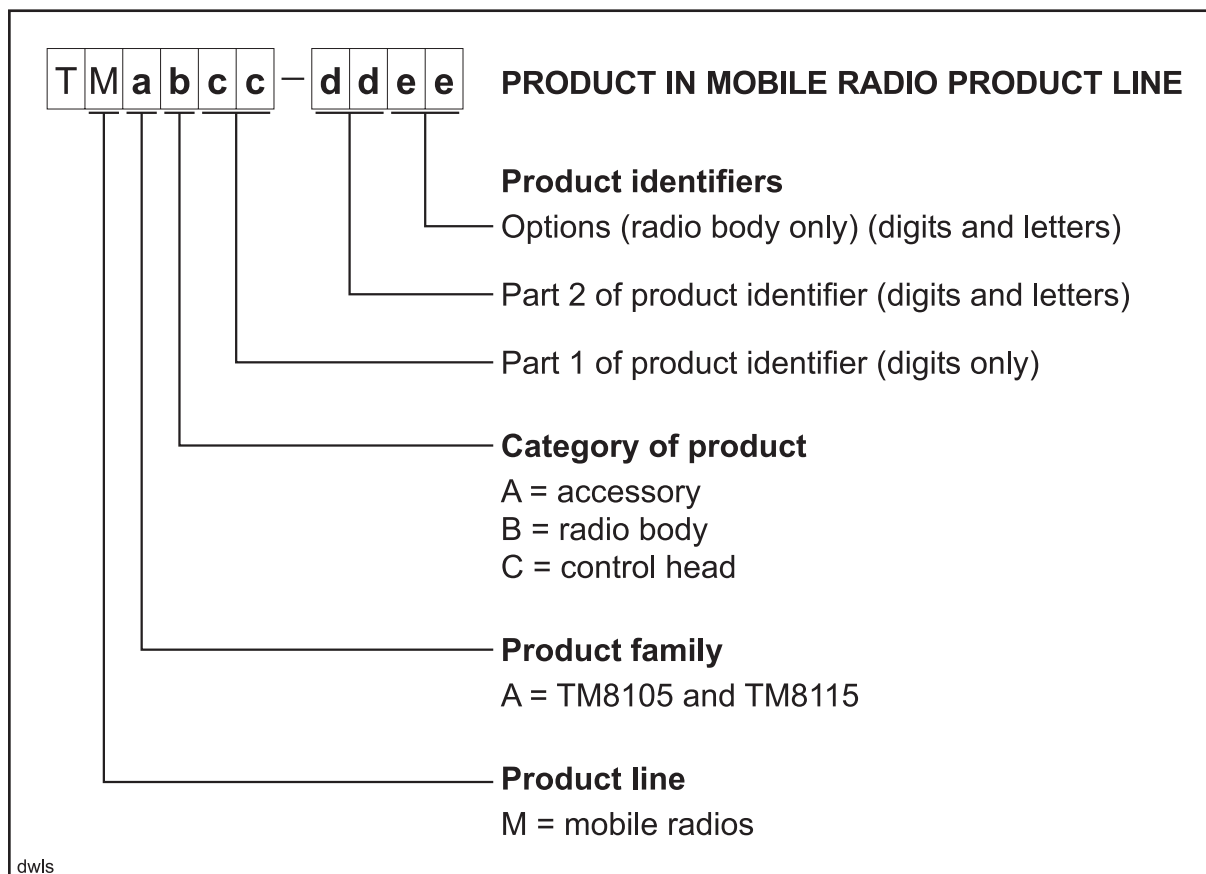

Figure 1.7 Scheme for the product codes assigned to products of the mobile radio product line

Restrictions regarding level-3 repairs

Only TEL and the ISC should carry out level-3 repairs. The level of technology employed in the TM8100 generation of radios is an order of magnitude greater than in earlier generations. This greater sophistication demands special equipment and techniques for level-3 repairs. Although other service centres are strongly advised not to attempt such repairs, those with sufficient resources and skilled technicians may wish to do so. These service centres should contact Technical Support for assistance and for the necessary documentation. TEL does not offer accreditation for level-3 repairs to any service centres other than the ISC.

1.5 Product Codes

Introduction

This subsection describes the product codes used to identify different products of the mobile radio product line. The product-code scheme in general is first explained, and then the product codes for the radio body and control head in particular. The purpose is solely to enable service technicians to identify the radio body and control head of a radio that has been delivered for repair.

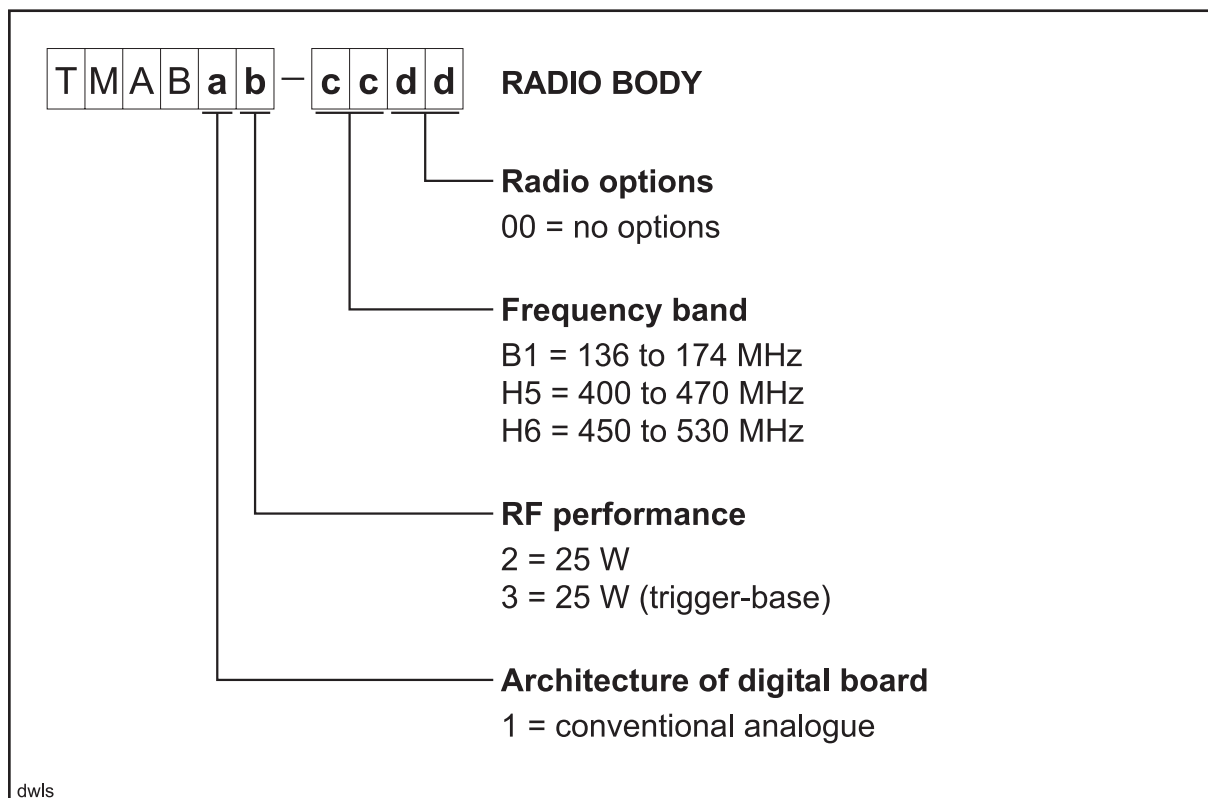

Figure 1.8 Scheme for the product codes currently in use for the radio body of TM8100 mobile radios

Limitations on use of product codes

The product codes discussed in this subsection are those in use at the time of publication. For up-to-date information refer to the TaitWorld website. The explanations of the product codes are to aid identification only, and are not to be used as the basis for sales orders. There are two reasons for this: Firstly, an arbitrarily-constructed product code might apply to a product that, for compliance reasons, is restricted to certain markets. Secondly, a product with such a product code might not even exist.

General scheme for product codes

Individual products of the mobile radio product line are identified by product codes with the format:

TMabcc-ddee

where **a** and **b** are uppercase letters representing the product family and category of product respectively, and **cc**, **dd** and **ee** are characters that identify the specific product. The characters **ee** are applicable to the radio body only and identify different options. The product code scheme is summarised in Figure 1.7.

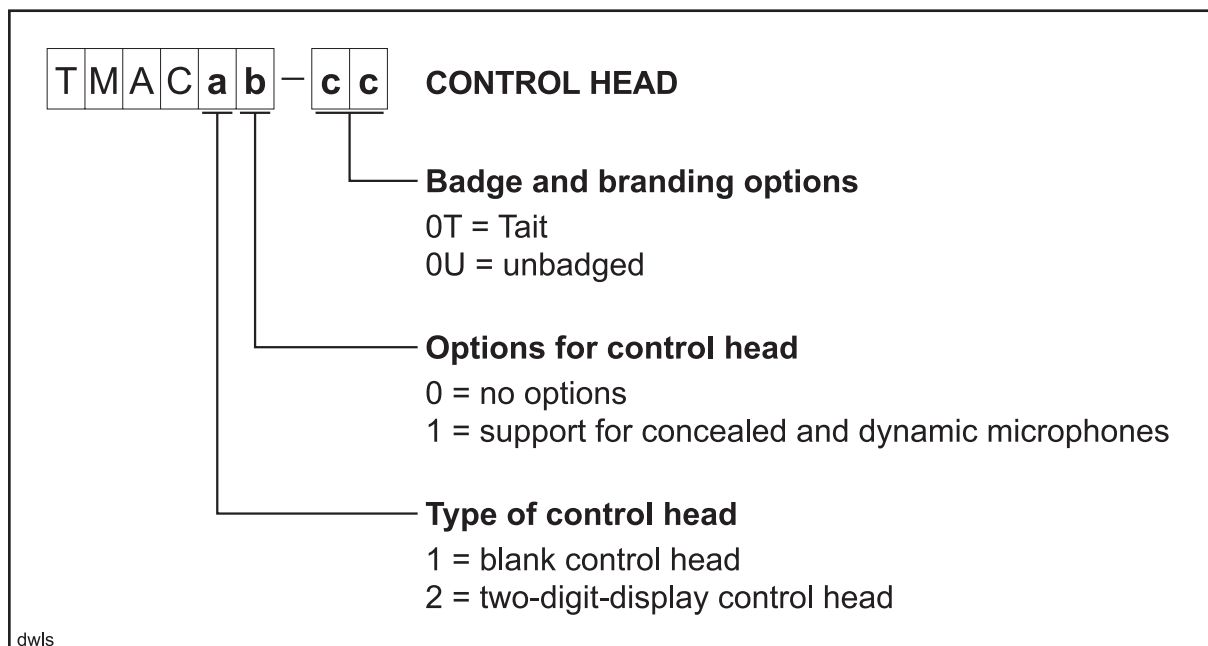

Figure 1.9 Scheme for the product codes currently in use for the control head of TM8100 mobile radios

Product families and categories

Examples of different product families within the mobile radio product line are the T700, T2000 and TM8100 radios. The TM8100 family is however the first to which the above product-code scheme applies. Examples of different product categories are radio bodies, control heads, and accessories. These are the only categories identified to date. The product codes for the TM8100 radio body and control head are discussed below; those for the accessory items are described in the accessories manual.

Product codes for radio body

The product codes for the TM8100 radio body have the format:

TMABab-ccdd

where **a** identifies the architecture of the digital board, **b** identifies the RF performance, **cc** is the letter-digit combination identifying the frequency band, and **dd** identifies any options selected. The characters **dd** are set to 00 for the default radio with no options added. For universal options available to all Customers, the digits 01 to 99 are used for **dd**. For custom options implemented for particular Customers, the letters AA to ZZ are used. The digits and letters identifying the universal and custom options are assigned sequentially. Figure 1.8 illustrates the product codes in use at the time of publication.

**Product codes
for control head**

The product codes for the TM8100 control head have the format:

TMAC**a**b-**cc**

where **a** identifies the type of control head, **b** identifies any options selected, and **cc** identifies badging and branding options. By type is meant whether the control head is a blank or two-digit-display control head; allowance is made for additional types in the future. Only the digits 1 to 9 are allowed for **a** (0 is not used), and the digits 0 to 9 for **b**; the latter is set to 0 when no options are added. Both letters and digits may be used for **cc**. The default for **cc** is 0T; on the two-digit-display control head the Tait logo is then displayed next to the LCD screen, and the product model code TM8115 is displayed above the speaker grill. Figure 1.9 illustrates the product codes in use at the time of publication.

2 General Description

Scope of section

This section comprises a general description of the radio body and control head of TM8100 mobile radios. Firstly, the architecture of the radio is described. Secondly, the operation of the control-head circuitry is summarised. Finally, the principles of operation of the radio are given in three separate subsections.

2.1 Architecture of Radio

Introduction

In this subsection the architecture of the radio is described. The different circuit modules of the control-head, main and digital boards introduced in Section 1 are identified. The optional circuit boards mentioned in Section 1 are covered in other manuals.

Control head

The two-digit-display control head houses a control-head board with the circuitry needed for the controls and indicators on the front panel. There is provision for an optional board for use with dynamic microphones or with a concealed microphone inside the control head. There is also provision for the fitting of an optional third-party circuit board in the blank control head.

The operation of the control-head board is summarised in Subsection 2.2. The circuit board for concealed and dynamic microphones is described in the accessories manual. The fitting of third-party circuit boards in the blank control head is discussed in the application manual for 3DK hardware developers.

Radio body

The radio body houses a main board with the transmitter, receiver and associated circuitry, and a digital board with the microprocessor and associated circuitry. The digital board is reflow-soldered to the main board. There is also provision for an internal options board to be connected to the main board.

The different circuit modules of the main board are discussed below and the operation of the circuitry is described in Subsection 2.3 to Subsection 2.5. The different internal options boards are discussed in the accessories manual and the 3DK manuals.

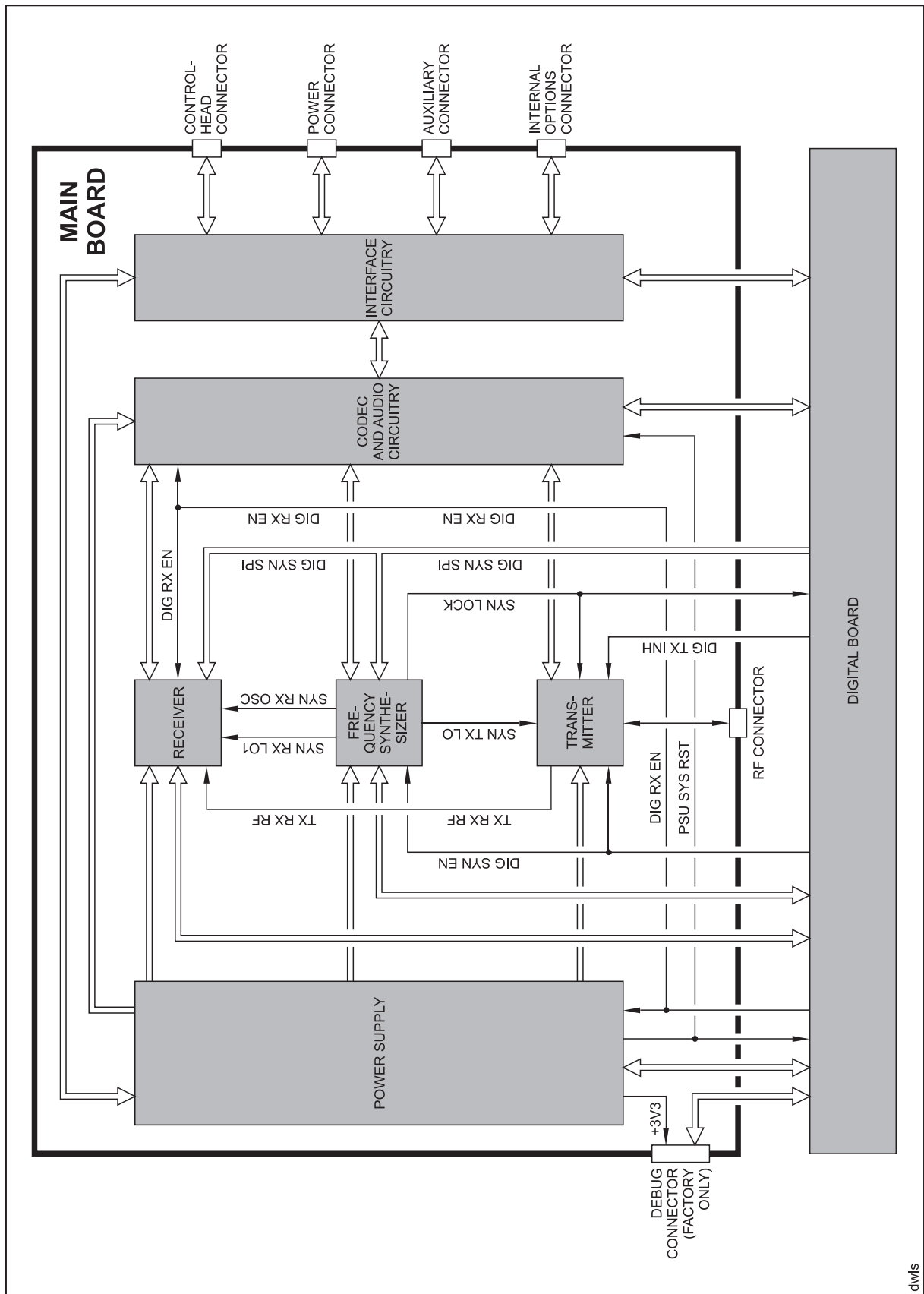

Figure 2.1 Block diagram of the main board of the radio body

Modules of main board

The control-head, main and digital boards, and the connectors on the boards, are illustrated in Figure 1.6 of Section 1. Figure 2.1 is a block diagram showing the main and digital boards and the circuit modules of the main board. These modules are:

- transmitter
- receiver
- frequency synthesizer
- CODEC and audio circuitry
- power supply
- interface circuitry

Software plays a prominent role in the functioning of the TM8100 radio. For describing the operation of the radio the software must be included with the above modules. This is considered further below.

Operation of radio

Figure 2.2 is a simplified block diagram of the transceiver architecture showing the hardware modules integrated with the software modules. The same DSP device includes the software that controls the transceiver and the software constituting the digital-signal-processing blocks in Figure 2.2. The operation of the radio is then best described with reference to Figure 2.2 and with a division into the following three parts:

- operation in receive mode
- operation in transmit mode
- operation of frequency synthesizer

Operational descriptions of these three parts are given in Subsection 2.3 to Subsection 2.5 respectively.

2.2 Operation of Control-head Circuitry

User interface

In this subsection the operation of the control-head circuitry is summarised. The standard control head provides a user interface consisting of:

- two-digit seven-segment LCD
- up and down channel-selection keys
- four programmable function keys
- on/off push-button key
- LED indicators
- volume control
- internal speaker
- microphone connector

The microphone connector may also be used for the connection of a handset or programming lead. If required, a concealed microphone may be fitted inside the control head.

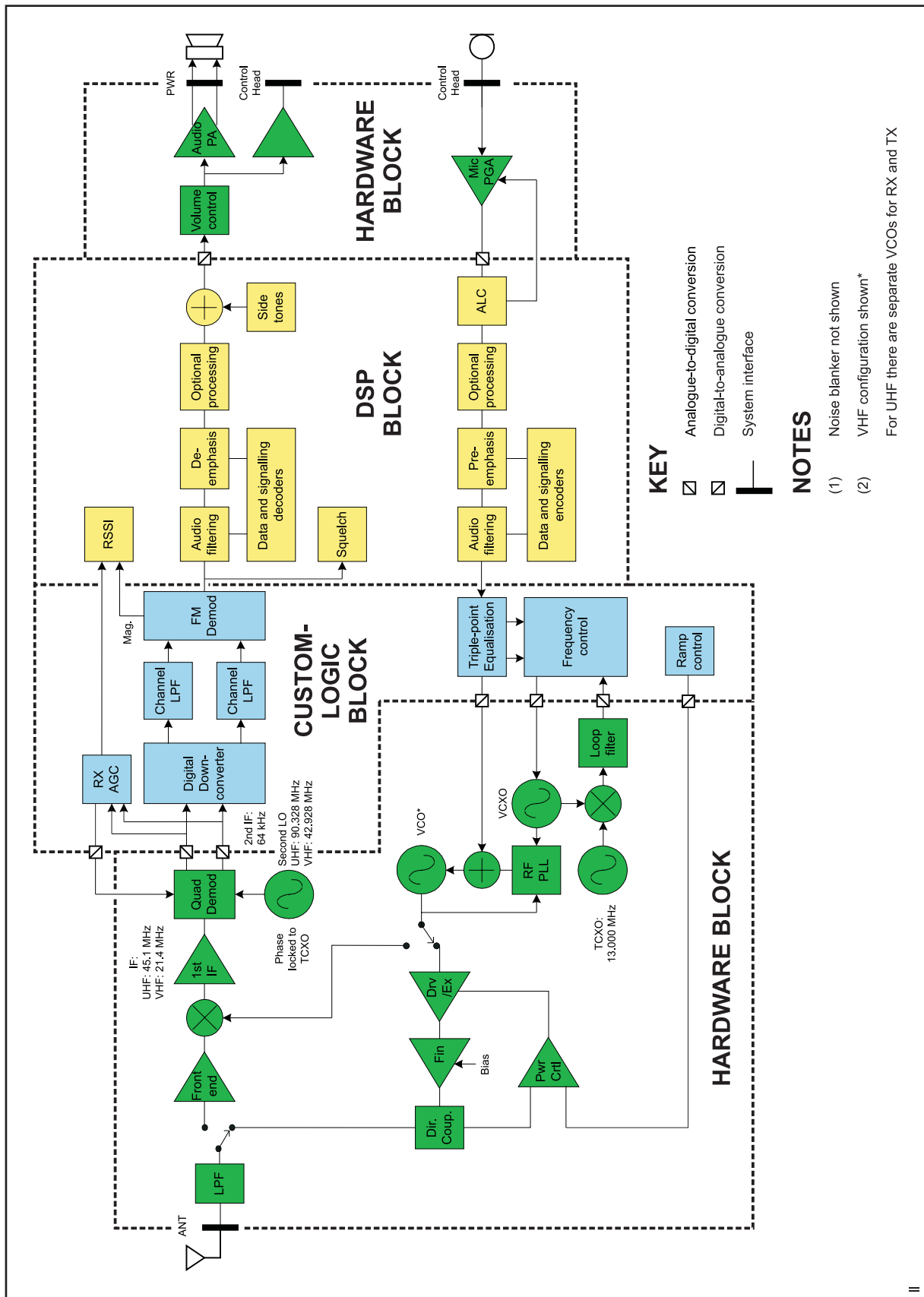

Figure 2.2 Architecture of the TM8100 transceiver

Connectors and circuit boards There is an 18-way electrical interface between the control head and radio body. The physical connection is via an 18-way loom. The control head normally contains a single PCB assembly called the control-head board. If a dynamic microphone is used or a concealed microphone fitted, a small circuit board must be mounted on the control-head board. The added board has the necessary amplification, filtering and switching functions. The internal speaker is connected to the control-head board via a lead with a mating connector so that it can be easily disconnected.

Control-head board The control-head board does not include a microprocessor. A synchronous bi-directional serial interface provides communication of key status, LCD and LED-indicator data between the radio body and the control head. On the control-head board the serial data are converted to or from parallel form by a number of shift registers for the keys and indicators. For the LCD, the serial data are fed to a driver IC that converts the serial data to a form suitable for the LCD itself. The keys are scanned and the LCD and LED indicators updated approximately every 50 ms.

2.3 Operation in Receive Mode

Receive path In this subsection the functioning of the radio in the receive mode is described. As shown in Figure 2.2, the receive path exists in three different domains:

- hardware
- custom logic
- DSP

The front-end hardware amplifies and image-filters the received RF spectrum, then down-converts the desired channel frequency to a first intermediate frequency IF1 of 45.1 MHz (UHF) or 21.4 MHz (VHF) where coarse channel filtering is performed. The first LO signal is obtained from the frequency synthesizer. The output of the first IF is then down-converted using an image-reject mixer to a low IF of 64 kHz.

Quadrature demodulator The LO for the image-reject mixer (quadrature demodulator) is synthesized and uses the TCXO as a reference. This ensures good centring of the IF filters and more consistent group-delay performance. The quadrature demodulator device has an internal frequency division of 2 so the second LO operates at $2 \times (\text{IF1} + 64 \text{ kHz})$. The quadrature output from this mixer is fed to a pair of ADCs with high dynamic range where it is oversampled at 256 kHz and fed to the custom logic device.

Custom logic	The remainder of the channel filtering is performed in custom logic. Different filter shapes are possible to accommodate the various channel spacings and data requirements. These filters provide the bulk of adjacent channel selectivity for narrow-band operation. Each filter has a linear phase response so that good group-delay performance for data is achieved. The filters also decimate the sample rate down to 48 kHz. Custom logic also performs demodulation, which is multiplexed along with AGC and amplitude data and fed via a single synchronous serial port to the DSP. The stream is demultiplexed and the demodulation data stream processed further to meet audio requirements.
Automatic gain control	The AGC is used to limit the maximum signal level applied to the image-reject mixer and ADCs in order to meet the requirements for intermodulation and selectivity performance. Hardware gain control is performed by a variable gain amplifier within the quadrature demodulator device driven by a 10-bit DAC. Information about the signal level is obtained from the IQ data output stream from the ADCs. The control loop is completed within custom logic. The AGC will begin to reduce gain when the combined signal power of the wanted signal and first adjacent channels is greater than about -70 dBm. In the presence of a strong adjacent-channel signal it is therefore possible that the AGC may start acting when the wanted signal is well below -70 dBm.
Noise squelch	The noise squelch process resides in the DSP. The noise content above and adjacent to the voice band is measured and compared with a preset threshold. When a wanted signal is present, out-of-band noise content is reduced and, if below the preset threshold, is indicated as a valid desired signal.
Noise blanking	Provision has been made for an optional noise blanker to remove common sources of electrical interference such as vehicle ignition noise. The noise blanker functions by sampling the RF input to the receiver for impulse noise and momentarily disconnecting the first LO for the duration of the impulse. The response time of the noise blanker is very fast (tens of nanoseconds) and is quicker than the time taken for the RF signal to pass through the front-end hardware, so that the LO is disabled before the spike reaches the IF stage where it could cause crystal filter ring. The noise blanker is fitted as standard for the VHF band.
Monitoring	The lock-detect signal of the second LO synthesizer is monitored at least every 100 ms. If the PLL fails to indicate lock within 10 ms of programming, an error is reported by the control software. If an out-of-lock condition occurs during run-time, then an audible indication will be given and recovery repeatedly attempted.

Calibration

The following items within the receiver path are calibrated:

- Front-end tuning
- AGC
- Noise squelch
- RSSI

Information on the calibration of these items is given in the on-line help facility of the calibration application.

Audio processing

Raw demodulated data from the receiver is processed within the DSP. The sample rate at this point is 48000 samples per second with signal bandwidth limited only by the IF filtering. Scaling (dependent on the bandwidth of the RF channel) and noise-peak limiting are then applied to normalise the signal level for the remaining audio processing. The sample rate is decimated to 8000 samples per second and then low-pass filtered at 3 kHz, before being passed to the subaudible decoders and on for further filtering in the main path. High-pass filtering is then applied to remove the subaudible signalling and rumble from the audio signal. The filter cut frequency is made higher when subaudible signalling is expected compared to when it is not. This allows full low-frequency audio response on non-subaudible channels.

Signal source for speaker

The output of the high-pass filter is where in-band signalling decoders obtain their input signal. The signal is then de-emphasised. The next process in the chain is a multiplexer to select a signal source to feed the main path to the speaker. The sources are as follows:

- receive path
- confidence-tone generator
- transmit confidence side-tone

The confidence-tone generator is activated for such events as key-presses or alarms; the level from this block is a fixed proportion (in the order of -10 dB) relative to full scale in the receive path. Regarding the transmit confidence side-tone, the output of the transmit signalling encoders can be fed to the speaker to give the user confidence that the signalling message is being sent; the level from this block is a fixed proportion (in the order of -10 dB) relative to full scale in the receive path.

Combined audio and side-tone signal

The combined audio and side-tone signal is converted to analogue form by a 16-bit DAC, and then bandpass filtered by a switched cap filter (100 Hz to 3.3 kHz) to remove alias components. This is followed by a programmable-gain amplifier with 45 dB range that performs volume control and muting. The volume control is logarithmic, with steps of 1.5 dB. Here, a side-tone from an options board can be summed in with the receive audio.

Output to speakers

After side-tone summation the audio is fed to an audio power amplifier and to the control head via a buffer amplifier. The output configuration of the audio power amplifier is balanced and drives an internal speaker and, optionally, an external speaker. The speaker loads are connected in parallel rather than being switched. The power delivered to each speaker is limited by its impedance. The internal speaker has 16-ohm impedance whereas the external speaker can be as low as 4 ohms.

2.4 Operation in Transmit Mode

RF power amplifier and switching

In this subsection the functioning of the radio in the transmit mode is described. Refer to Figure 2.2. The RF power amplifier is a four-stage line-up with approximately 42 dB of power gain. The output of the frequency synthesizer is first buffered to reduce kick during power ramping. The buffer output goes to a broad-band exciter IC that produces approximately 200 mW output. This is followed by an LDMOS driver producing up to 2 W output that is power-controlled. The final stage consists of two parallel LDMOS devices producing enough power to provide 25 W at the antenna.

Output of RF power amplifier

The output of the RF power amplifier passes through a dual-directional coupler, used for power control and monitoring, to the PIN switch. The PIN switch toggles the antenna path between the receiver and transmitter in receive and transmit modes respectively. Finally, the output is low-pass-filtered to bring harmonic levels within specification.

Power control

The steady-state power output of the transmitter is regulated using a hardware control loop. The forward power output from the RF power amplifier is sensed by the directional coupler and fed back to the power control loop. The PA output power is controlled by varying driver gate bias voltage that has a calibrated maximum limit to prevent overdrive. The reference voltage for the control loop is supplied by a 13-bit DAC. The system driving the DAC supplies the steady-state voltage for a given power level as determined by factory calibration. The bandwidth of the loop is high to ensure that it does limit the ramping slope and has approximately 25 dB power control range. At low power settings the final bias is reduced to improve efficiency and maintain power control range.

Ramping

Power ramp-up consists of two stages:

- bias
- power ramping

The timing between these two stages is critical to achieving the correct overall wave shape in order to meet the specification for transient ACP.

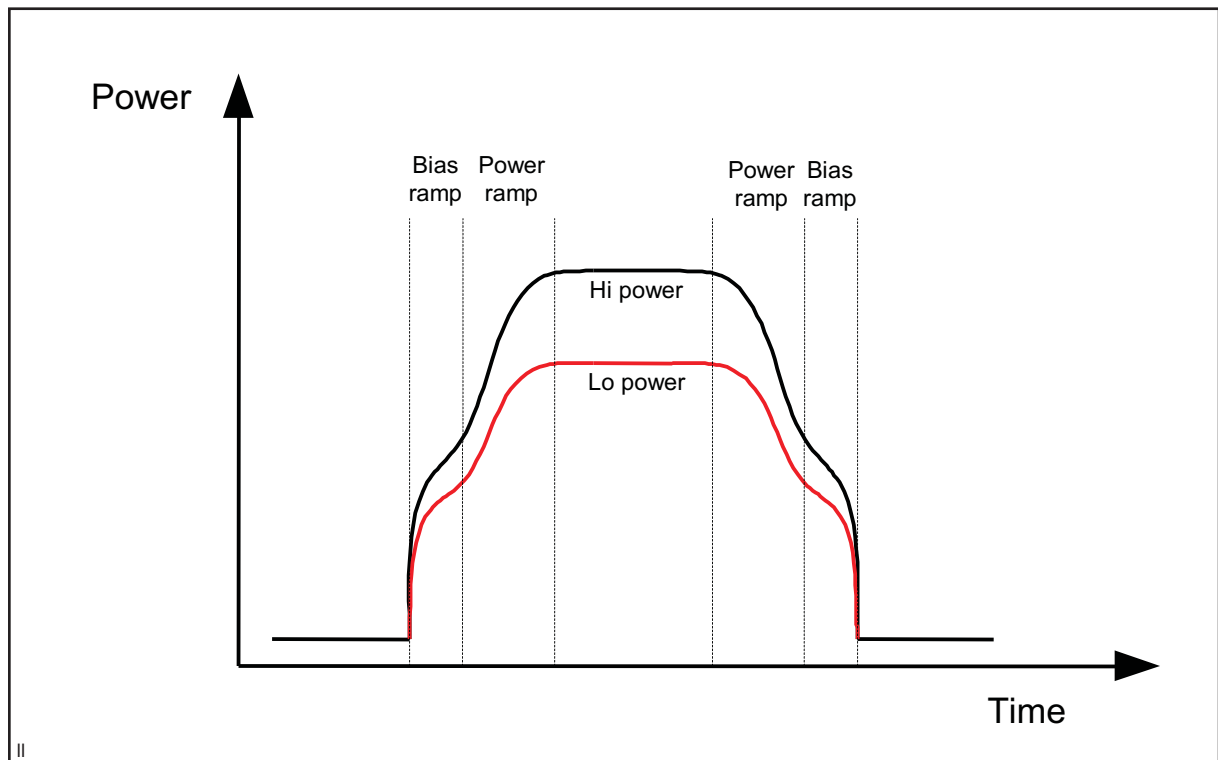

Figure 2.3 Typical ramping waveforms

Bias ramp-up

The steady-state final-stage bias level is supplied by an 8-bit DAC programmed prior to ramp-up but held to zero by a switch on the DAC output under the control of a TX INHIBIT signal. Bias ramp-up begins upon release by the TX INHIBIT signal with the ramping shape being determined by a low-pass filter. Owing to power leakage through the PA chain, ramping the bias takes the PA output power from less than -10 dBm to approximately 25 dB below steady-state power.

Power ramp-up

The power ramp signal is supplied by a 13-bit DAC that is controlled by custom logic. The ramp is generated using a look-up table in custom logic memory that is played back at the correct rate to the DAC to produce the desired waveform. The ramp-up and ramp-down waveforms are produced by playing back the look-up table in forward and reverse order respectively. For a given power level the look-up table values are scaled by a steady-state power constant so that the ramp waveform shape remains the same for all power levels. Typical ramping waveforms are shown in Figure 2.3.

Inhibiting of transmitter

The transmitter will be inhibited when any of the following conditions exists:

- frequency synthesizer out of lock
- power supply voltage outside correct operating range
- software inhibit present

The last-named signal would normally initiate the start of ramp-up.

Audio processing	The input to the transmitter path begins at the microphone input. There are two microphone sources; a fist microphone connected to the control head and an auxiliary microphone connected via the auxiliary or options connector. Only electret-type microphones are supported. Support for optional dynamic fist microphones is facilitated by a hardware amplifier and filter in the control head.
Processing of microphone signal	The CODEC performs microphone selection and pre-amplification. The microphone amplifier consists of a by-passable amplifier with a fixed gain of 20 dB followed by a programmable-gain amplifier with 0 to 22 dB gain giving up to 42 dB total control range. The amplified microphone signal is converted to a digital stream by a 16-bit ADC and then bandpass-filtered (0.1 to 3.2 kHz). The digital stream is transported to the DSP for further processing.
Automatic level control	The ALC follows, and is used to effectively increase dynamic range by boosting the gain of the microphone pre-amplifier under quiet conditions and reducing the gain under noisy acoustic conditions. The ALC function resides in the DSP and controls the microphone pre-amplifier gain in the CODEC. The ALC has a fast-attack (about 10 ms) and slow-decay (up to 2 s) characteristic. For the peak signal provided to the DSP blocks that are next in the chain, this characteristic ensures that the signal is regulated near full scale to maximise dynamic range.
Final processing of audio signal	The audio is then high-pass filtered to remove any frequency components that may exist in the subaudible signalling band and prevent limiter overload. The encode signal for in-band signalling, if active, is summed with the audio. Pre-emphasis is then applied, followed by a limiter to remove transients that may have passed through the ALC. A low-pass filter then removes unwanted limiter artefacts and also interpolates the sample rate up to 48 kHz that is required for the interface to the frequency synthesizer. At this point subaudible signalling, if active, is summed with the audio. The final process is to scale the signal level (and hence the deviation) to match the RF channel bandwidth and compensate for subaudible signalling if added. The signal is then passed to the frequency synthesizer where it is used as the modulation source.

2.5 Operation of Frequency Synthesizer

Control loops

In this subsection the functioning of the frequency synthesizer is described. Note that patents are pending for several aspects of the synthesizer design. As may be seen from Figure 2.2, the frequency synthesizer consists of two main parts:

- RF PLL
- FCL

The FCL generates a high-stability reference frequency that can be both modulated and offset in fine resolution steps. The RF PLL has fast-locking capability but coarse frequency resolution. The FCL output is the reference frequency input for the RF PLL. It is frequency-locked to the TCXO, thereby acquiring the TCXO's frequency stability.

Modulation

In dual-point modulation systems the modulation is applied to both the frequency reference and the VCO in the RF PLL combining to produce a flat modulation response down to DC. Reference modulation is usually applied directly to the TCXO.

In the system employed in the TM8100 radio, the frequency reference is composed of the 13 MHz TCXO and the FCL, which itself requires dual-point modulation injection to allow modulation down to DC. With another modulation point required in the RF PLL, this system therefore requires triple-point modulation. The modulation cross-over points occur at approximately 30 and 300 Hz as determined by the closed loop bandwidths of the FCL and RF PLL respectively.

Frequency generation and acquisition

The RF PLL is an integer-N type and has frequency resolution of 25 kHz. Higher resolution cannot be achieved owing to acquisition-time requirements and so for any given frequency the error could therefore be as high as ± 12.5 kHz. This error is corrected by altering the reference frequency to the RF PLL. The FCL supplies the reference frequency and is able to adjust it up to ± 300 ppm with better than 0.1 ppm resolution (equivalent to better than 50 Hz resolution at the RF frequency). The FCL offset will usually be different for receive and transmit.

Fast frequency settling

Both the FCL and RF PLL employ frequency-acquisition speed-up techniques to achieve fast frequency settling. The frequency-acquisition process of the FCL and RF PLL is able to occur concurrently with minimal loop interaction owing to the very large difference in frequency step size between the loops.

Frequency-acquisition of RF PLL

In the RF PLL the loop bandwidth is initially set high by increasing the charge pump current and reducing time constants in the loop filter. As a result settling to within 1 kHz of the final value occurs in under 3 ms. In order to meet noise performance requirements the loop parameters are then switched to reduce the loop bandwidth. There is a small frequency kick as the loop bandwidth is reduced. Total settling time is under 4.5 ms.

Frequency-acquisition of FCL

The FCL utilises self-calibration techniques that enable it to rapidly settle close to the final value while the loop is open. The loop is then closed and settling to the final value occurs with an associated reduction in noise. The total settling time is typically less than 4 ms.

Monitoring

The lock detect signals of both the FCL and RF PLL are monitored by the software. This is performed at least every 100 ms. If an out-of-lock condition occurs during operation, then an audible indication will be given and recovery repeatedly attempted.

Calibration

The following items are calibrated in the frequency synthesizer:

- Nominal frequency
- K_{vco}
- K_{vcxo}
- VCO deviation

Calibration of the nominal frequency is achieved by adding a fixed offset to the FCL nominal frequency; the TCXO frequency itself is not adjusted. The items K_{vco} and K_{vcxo} are the control sensitivities of the RF VCO (in MHz/V) and VCXO (in kHz/V) respectively. The latter has temperature compensation.

3 Disassembly and Re-assembly of Radio

Introduction

This section covers the disassembly and re-assembly procedures entailed in level-1 repairs of the TM8100 radio. These procedures are:

- detachment of control head
- disassembly of control head
- disassembly of radio body
- re-assembly of radio body
- re-assembly and attachment of control head

The procedures are detailed in Subsection 3.1 to Subsection 3.5 respectively. A brief outline of the overall level-1 repair procedure itself is given below.



Important Observe anti-static precautions when servicing the TM8100 radio in order to avoid damage caused by static discharges.

Outline of level-1 repair procedure

For level-1 repairs first determine whether the control head or radio body is faulty. Do so by exchanging the control head for a spare control head. (Detach the control head as described in Subsection 3.1.) If the fault is rectified, the original control head is faulty; if not, the radio body is faulty. In the case of a faulty two-digit control head, also exchange the control-head loom for a spare loom. If the fault is rectified, the original loom is faulty; if not, the control head itself is faulty. After thus isolating the fault, repair a faulty control head and a faulty radio body as indicated in the following two paragraphs respectively.

Control head is faulty

If the control head is faulty, first inspect the control head for obvious damage as described in Subsection 3.1. Replace any damaged part or assembly; this might require removing the control-head board as described in Subsection 3.2. If there is no obvious damage, replace the control-head board. In either case, re-assemble the radio as described in Subsection 3.5, and subject the radio to a final test.

Radio body is faulty

If the radio body is faulty, the main-board assembly will need replacement. However, the control head should also be inspected for damage as described above, and any damage rectified. Next, open the radio body, remove the main-board assembly, and obtain a replacement assembly. The procedure is described in Subsection 3.3 and includes inspecting the radio body and rectifying any damage. Then re-assemble the radio body as described in Subsection 3.4 and re-attach the control head. If necessary, recalibrate the radio. Finally, reprogram and test the radio.

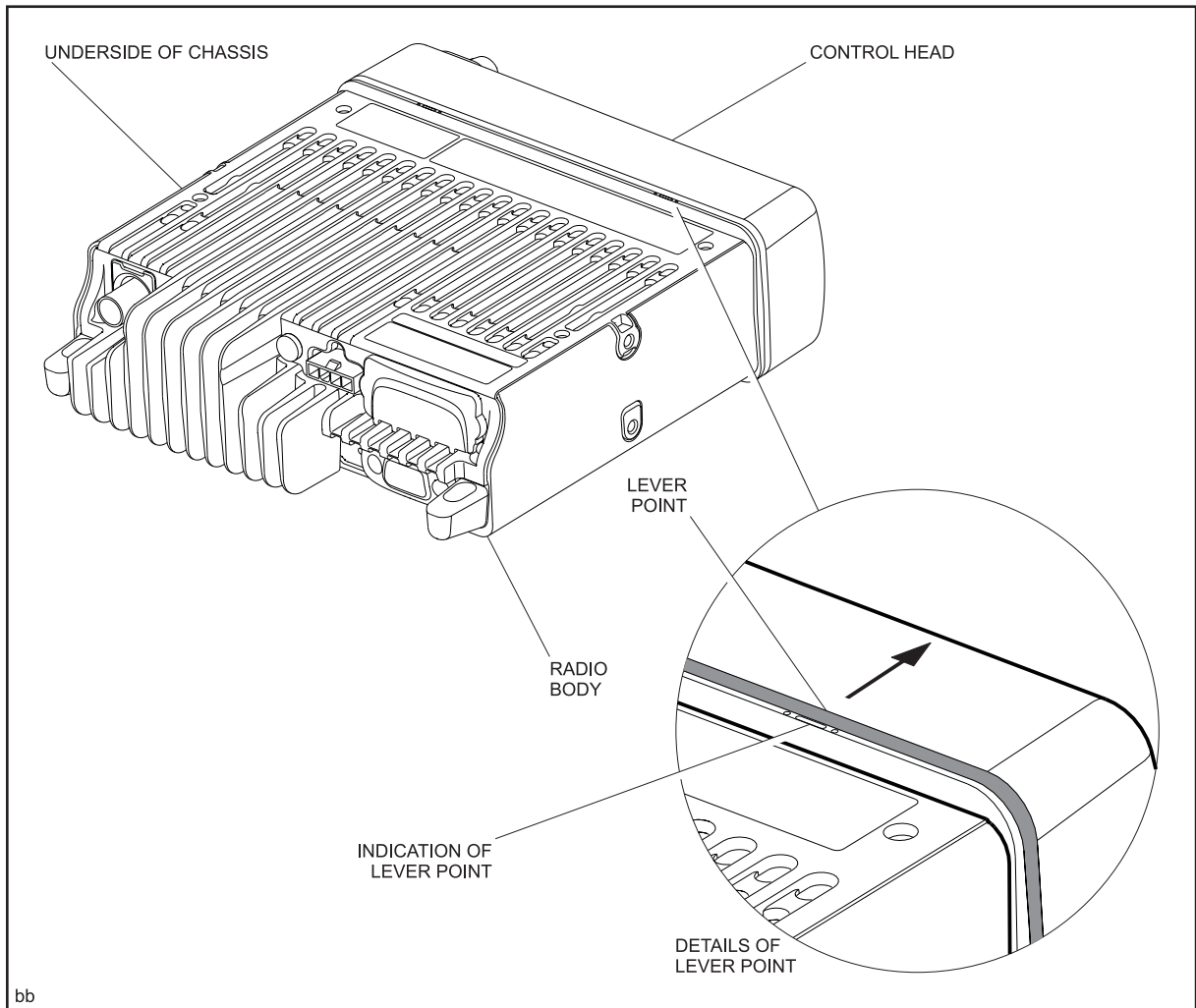

Figure 3.1 Lever points for detaching the control head from the radio body

3.1 Detachment of Control Head

Detach control head

Whether the control head or the radio body is faulty, the control head needs to be detached from the radio body. Do so as follows:

1. Note which way up the control head is attached to the radio body. The control head may be oriented with the underside of the radio body either at the top or bottom. The configuration depends on the Customer's installation, and the radio will need to be returned to the Customer with the same configuration.
2. Disconnect the radio from any test equipment or power supply.
3. Note the two points where the control head should be levered off the radio body. As shown in Figure 3.1, these points are indicated by dot-dash-dot marks on the underside of the radio body. The lever point is between the rubber seal and the front panel of the control head. (The seal is called the control-head seal.)
4. At each of the above lever points, insert the blade of a medium-sized (about 5 mm) flat-bladed screwdriver and lever off the control head.
5. After detaching the control head, disconnect the control-head loom at the connector on the radio body. Refer to Figure 3.2.
6. Inspect the control head and loom as described below.

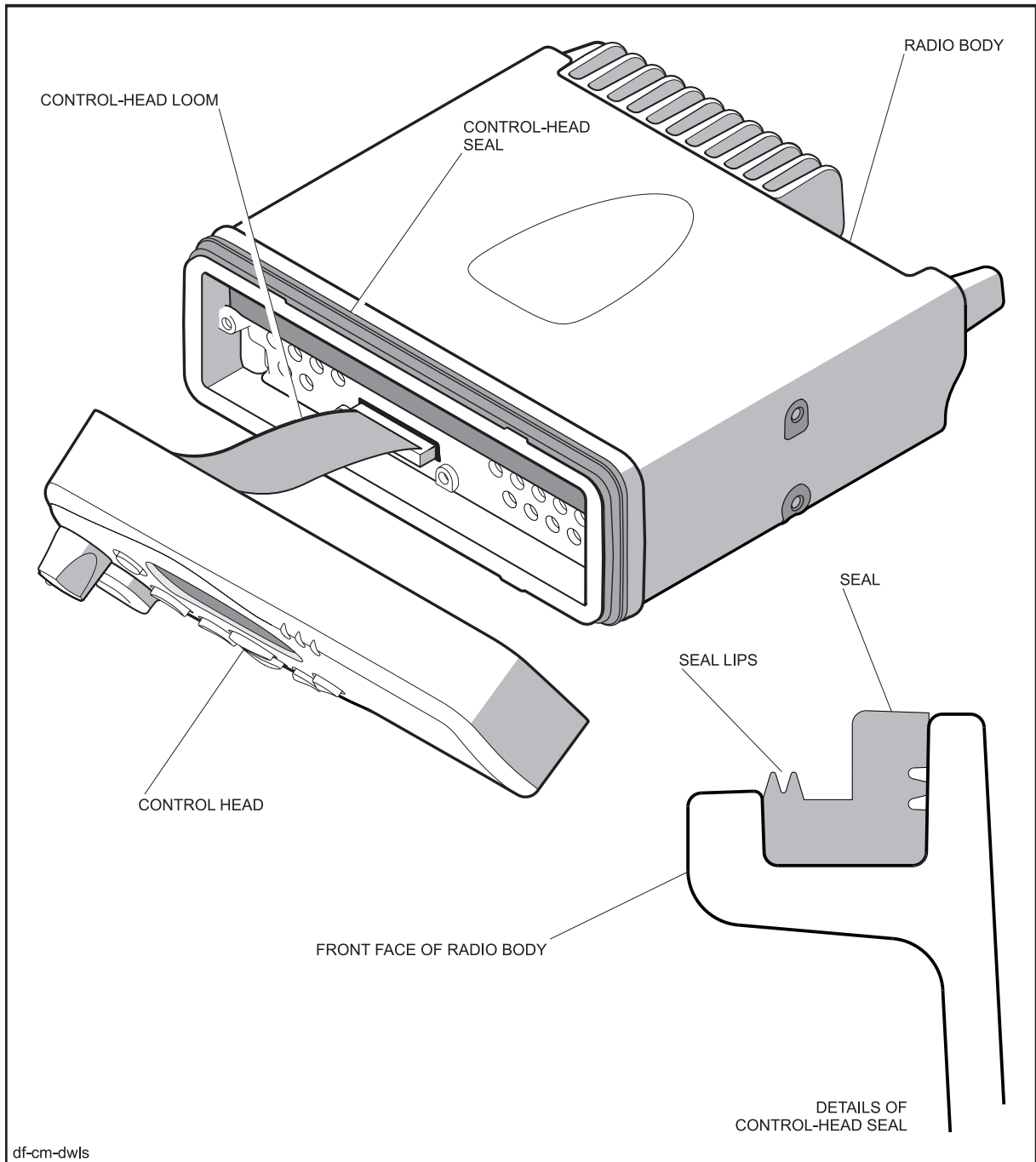
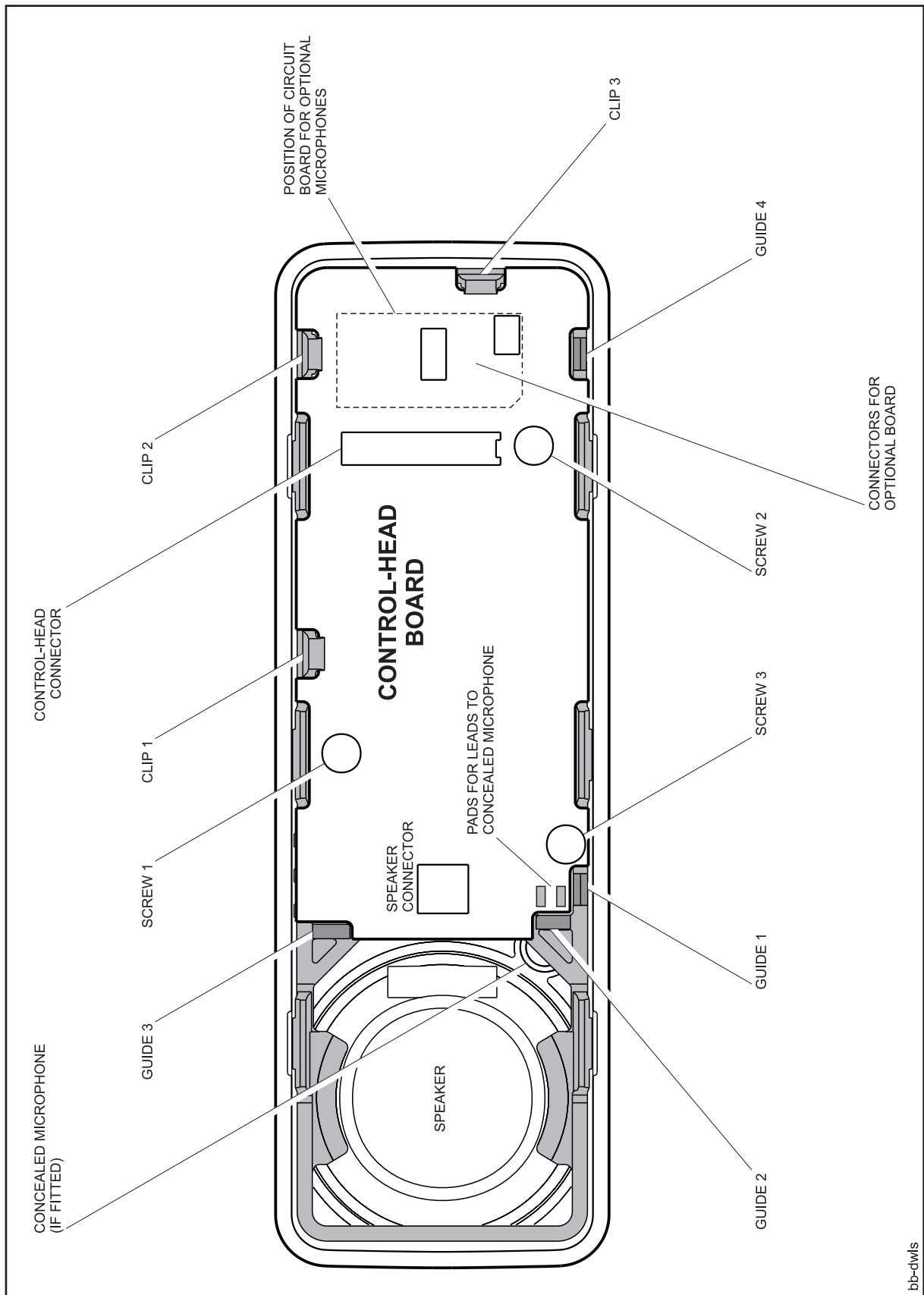

Figure 3.2 Details of the seal between the radio body and control head

Inspect mechanical parts

Regardless of the reason for detaching the control head, it is advisable to inspect the mechanical parts for damage. Check for and rectify any damage as follows:

1. Inspect the control-head loom. If the loom has obvious physical damage, replace it with a spare loom from Spares kit 1. The product code and contents of the kit are listed in Subsection 3.2.
2. Inspect the control-head seal. Refer to Figure 3.2, which shows a cross-section of the seal. Check for any sign of deformation, cuts or tears. Pay particular attention to the two lips of the seal.
3. If the seal is damaged, replace it with a spare seal from Spares kit 7. This kit contains a set of these seals.
4. Inspect the control head for signs of damage. Check for cracked, broken or burnt parts. In a two-digit-display control head the parts to inspect are the volume-control knob, keypad, lens, space-frame, speaker and, if fitted, concealed microphone. In a blank control head inspect the programming connector and attached loom.
5. If the inspection in Step 4 reveals no damage, continue with the repair of the radio. If there is damage in a two-digit-display control head, disassemble the control head and replace the damaged part or assembly as described in the next subsection. If there is damage in a blank control head, replace the complete control head; for the relevant product code refer to Subsection 1.5.



bb-dw/s

Figure 3.3 Plan view of the control head showing the control-head board

3.2 Disassembly of Control Head

Introduction

This subsection covers the disassembly of the two-digit-display control head and the replacement of a damaged part or assembly. There are two stages in the disassembly procedure:

- remove control head board
- replace damaged part or assembly

For the latter task the control-head board must first be removed. A separate circuit board for a concealed or dynamic microphone might or might not be mounted on the control-head board.

Remove control-head board

The procedure for removing the control-head board is as follows. Refer to Figure 3.3.

1. Pull off the knob from the volume-control potentiometer. Do not use any tools to do so as this might cause damage.
2. If a circuit board for a concealed or dynamic microphone is fitted, unplug it from the control-head board.
3. If a concealed microphone is fitted, unsolder the microphone leads from the control-head board. The leads are soldered to pads on the board as shown in Figure 3.3.
4. Note whether the speaker leads are connected to the control-head board. If so, disconnect the leads. The radio will need to be returned to the Customer in its original state.
5. Remove the screws securing the control-head board. The order of removal is immaterial. The screws are labelled screw 1 to screw 3 in Figure 3.3; these numbers are also inscribed on the PCB. The control-head board is now held down only by the clips labelled clip 1 to clip 3 in Figure 3.3.
6. Pull upwards on the edge of the control-head board adjacent to the speaker. At the same time push clip 1 and clip 2 by hand away from the board. The board will lift up slightly.
7. Push clip 3 away from the control-head board while simultaneously pressing on the shaft of the volume-control potentiometer. The board will be freed from the space-frame. Remove the board.
8. If the earlier inspections have not revealed any damaged parts, continue with the repair of the radio. If there is damage, continue with the disassembly of the control head and rectify the damage as described below.

Table 3.1 Contents of TMAA22-01 Spares kit 1 — parts of standard control head less control-head board

IPN	Description	Quantity
—	Front-panel assembly (see below for constituent parts)	1
311-01054-xx	Knob for volume-control potentiometer	1
—	Control-head-loom assembly (see below for constituent parts)	1
346-10030-08	3 x 8 PT screw for control-head board	3
Parts of front-panel assembly		
316-06786-xx	Front panel	1
312-01095-xx	Lens with Tait logo	1
365-01717-xx	Label for TM8115	1
209-00011-xx	Elastomeric strip	2
319-30073-xx	Space-frame	1
008-00031-xx	LCD	1
252-00011-xx	Speaker	1
307-01024-xx	Speaker membrane	1
311-03114-xx	Keypad	1
262-00003-xx	Short light pipe	2
262-00004-xx	Long light pipe	2
Parts of control-head-loom assembly		
219-02882-xx	Control-head loom	1
240-00021-41	Female-female adaptor for control-head connector	1
Note		
The characters xx in an IPN stand for the issue number. Items in the spares kit will always be the latest issue at the time the spares kit is produced.		

Front-panel assembly and Spares kit 1

The assembly remaining after the removal of the control-head board is called the front-panel assembly. A complete front-panel assembly is included in Spares kit 1; the other parts in the kit are a control-head loom, screws for the control-head board, and a volume-control knob. The contents of the kit, including the parts of the front-panel assembly, are listed in Table 3.1. The IPN of each spare part is given but, if applicable, not the issue number within the IPN. The latest issue of a particular part is always supplied.

Repair of front-panel assembly

There are two methods of repairing a damaged front-panel assembly:

- replace complete front-panel assembly
- replace damaged parts of front-panel assembly

Generally either method may be used. However, the latter method must be used if a concealed microphone is fitted or custom labels have been added to the front panel. The two methods are described separately below:

Replace front-panel assembly

To replace the complete front-panel assembly, discard the damaged assembly and obtain a replacement assembly from Spares kit 1. Leave the spare control-head loom, the screws, and the volume-control knob in the kit. Continue with the repair of the radio. Later in the repair procedure the control-head board will be fitted to the new front-panel assembly and the complete control head will be assembled.

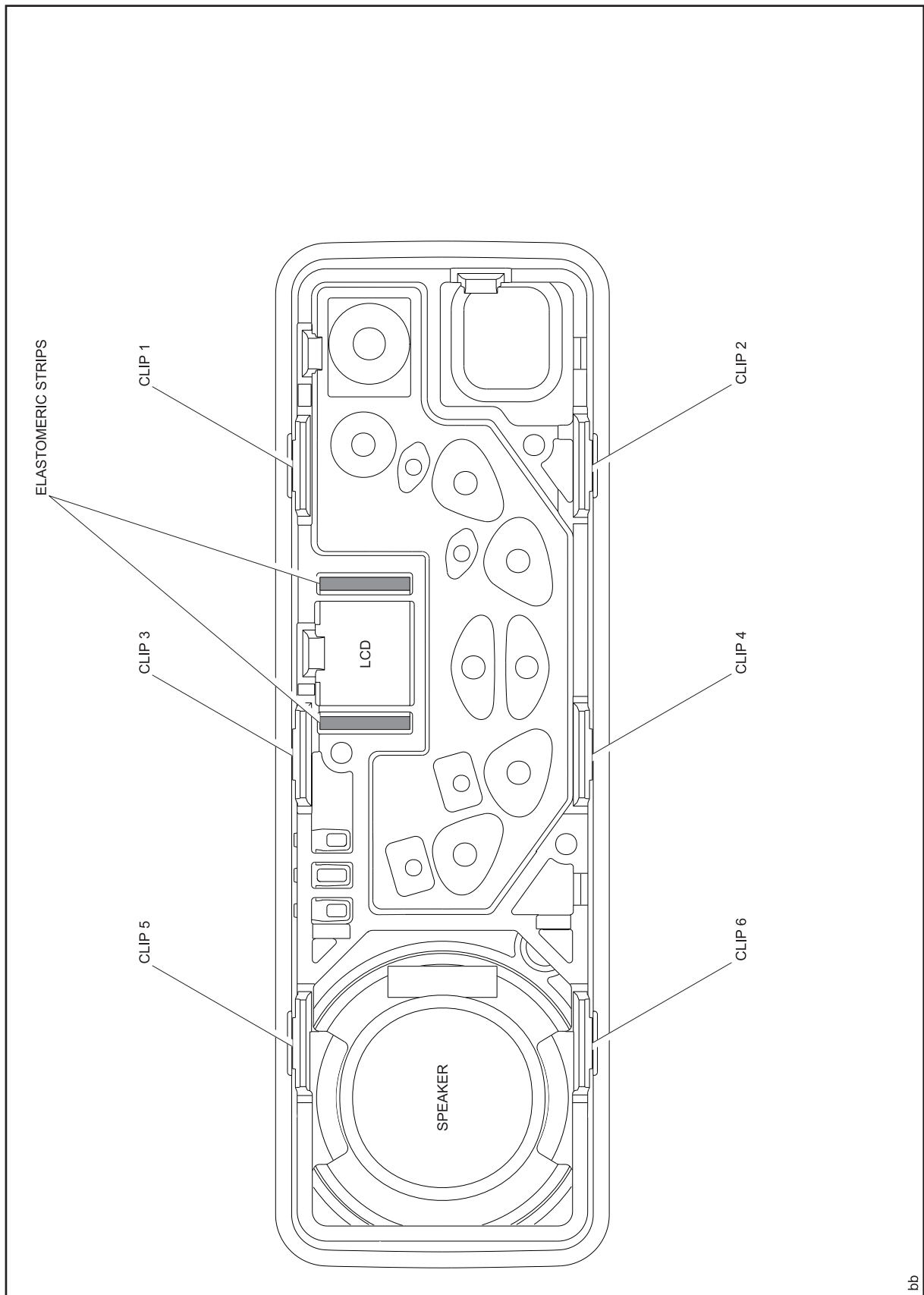

bb

Figure 3.4 Plan view of the control head with the control-head board removed

Replace damaged parts — disassembly task

To replace a damaged part, first disassemble the damaged front-panel assembly as well as a spare assembly from Spares kit 1. Proceed as follows. Refer to Figure 3.4.

1. Note the clips on the space-frame labelled clip 1 to clip 6 in Figure 3.4. These clips need to be released to remove the space-frame.
2. While pulling upwards on the space-frame at the corner where the microphone connector is situated, release the clips in the order: clips 1 and 2, 3 and 4, and then 5 and 6. To release each clip use a medium-sized (about 5 mm) flat-bladed screwdriver to lever the clip out of its recess. Pulling on the space-frame helps release the clips.
3. Pull the space-frame out when all six clips have been released.
4. Remove the elastomeric strips, speaker, LCD, keypad and, if fitted, concealed microphone.

Replace damaged parts — replacement task

Replace any of the following parts that inspection has shown to be damaged. Refer to the accessories manual regarding the replacement of a concealed microphone that has been damaged.

- elastomeric strips
- space-frame
- speaker
- keypad
- LCD
- front panel

Obtain replacement parts from the disassembled spare front-panel assembly. Discard the damaged parts and return unused spare parts to Spares kit 1. Note that spare front panels include the speaker membrane, lens and branding label; the LED light pipes are moulded into the panel. If any part of the front panel is damaged, including the membrane, lens and light pipes, replace the complete panel.

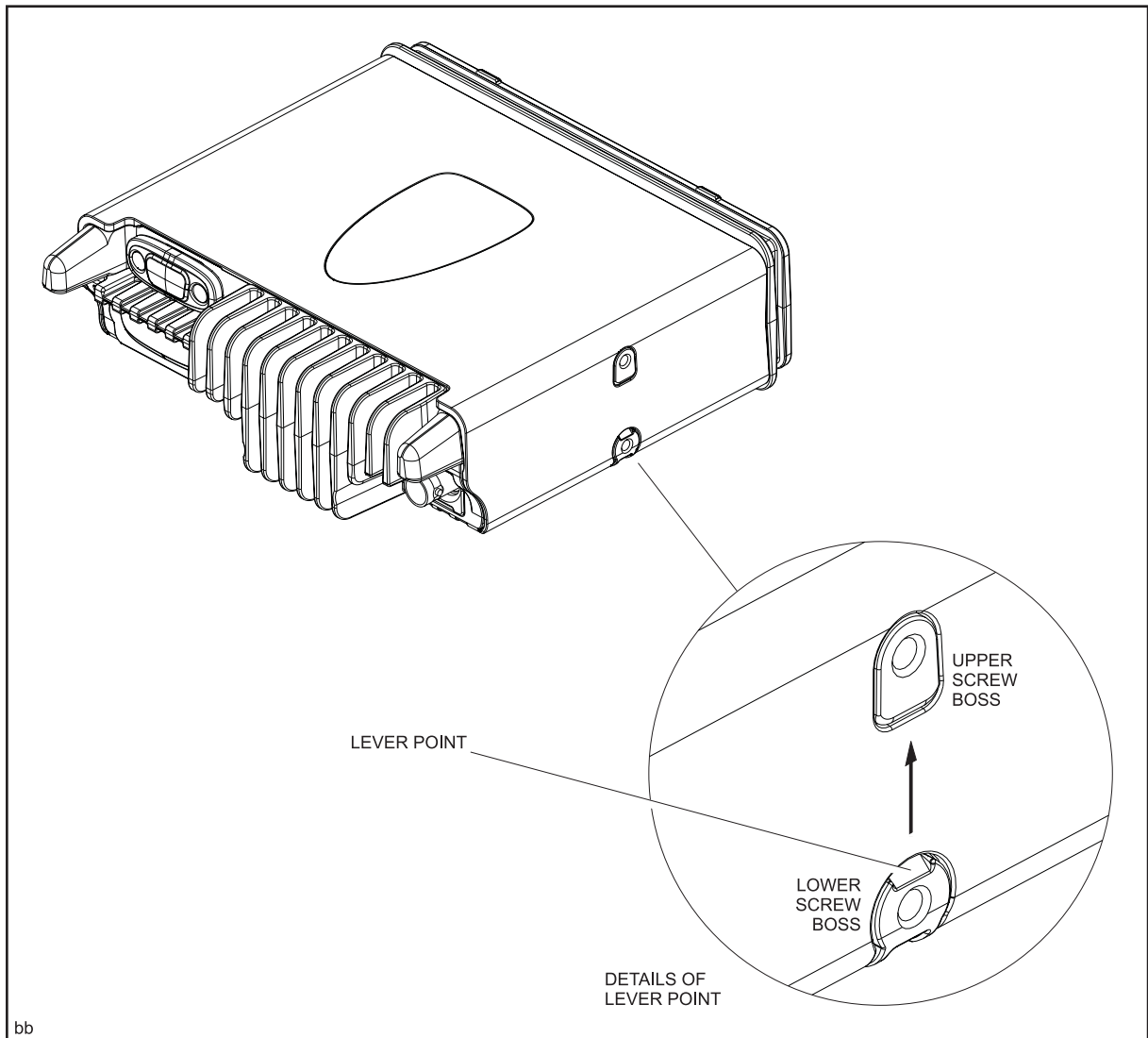

bb

Figure 3.5 Lever points for removing the cover of the radio body

3.3 Disassembly of Radio Body

Introduction

This subsection covers the disassembly of the radio body. There are two stages in the disassembly procedure:

- open radio body
- remove main-board assembly

The control head need not be detached before the radio body is opened, but it must be detached before the main-board assembly can be removed.

Open radio body

The first stage in disassembling the radio body is to remove the cover and lid. In the process it is advisable to inspect and, if necessary, replace the main seal in the lid. The procedure is included in the disassembly instructions:

1. Note the two screw bosses on each side of the chassis. The cover clips to the underside of each upper boss. Also note the two points where the cover should be levered off the radio body. As shown in Figure 3.5, each lever point is a slot above the lower screw boss.
2. Insert the blade of a small (about 3 mm) flat-bladed screwdriver in each of the above slots in turn. In each case push the screwdriver under the cover towards the upper screw boss. This will release the cover from the upper boss. Remove the cover.
3. Use a Torx T20 screwdriver to remove the four screws securing the lid of the radio body. The screws are shown in Figure 3.6.
4. Carefully remove the lid. If an options board is fitted, there will be an options loom connecting the main board in the chassis and the options board in the lid. If this is the case, place the lid next to the chassis as shown in Figure 3.7 and disconnect the loom.
5. Inspect the main seal in the lid for any sign of deformation, cuts or tears. Refer to Figure 3.7. If the seal is damaged, replace it with a spare seal from Spares kit 2. The contents of the kit are listed in Table 3.2. The IPN of each spare part is given but, if applicable, not the issue number within the IPN. The latest issue of a particular part is always supplied.
6. Inspect the radio body for damage to the cover and the seal for the RF connector, and for loss of the bungs for the auxiliary and external options connectors. Replace any lost or damaged part with a spare part from Spares kit 2.

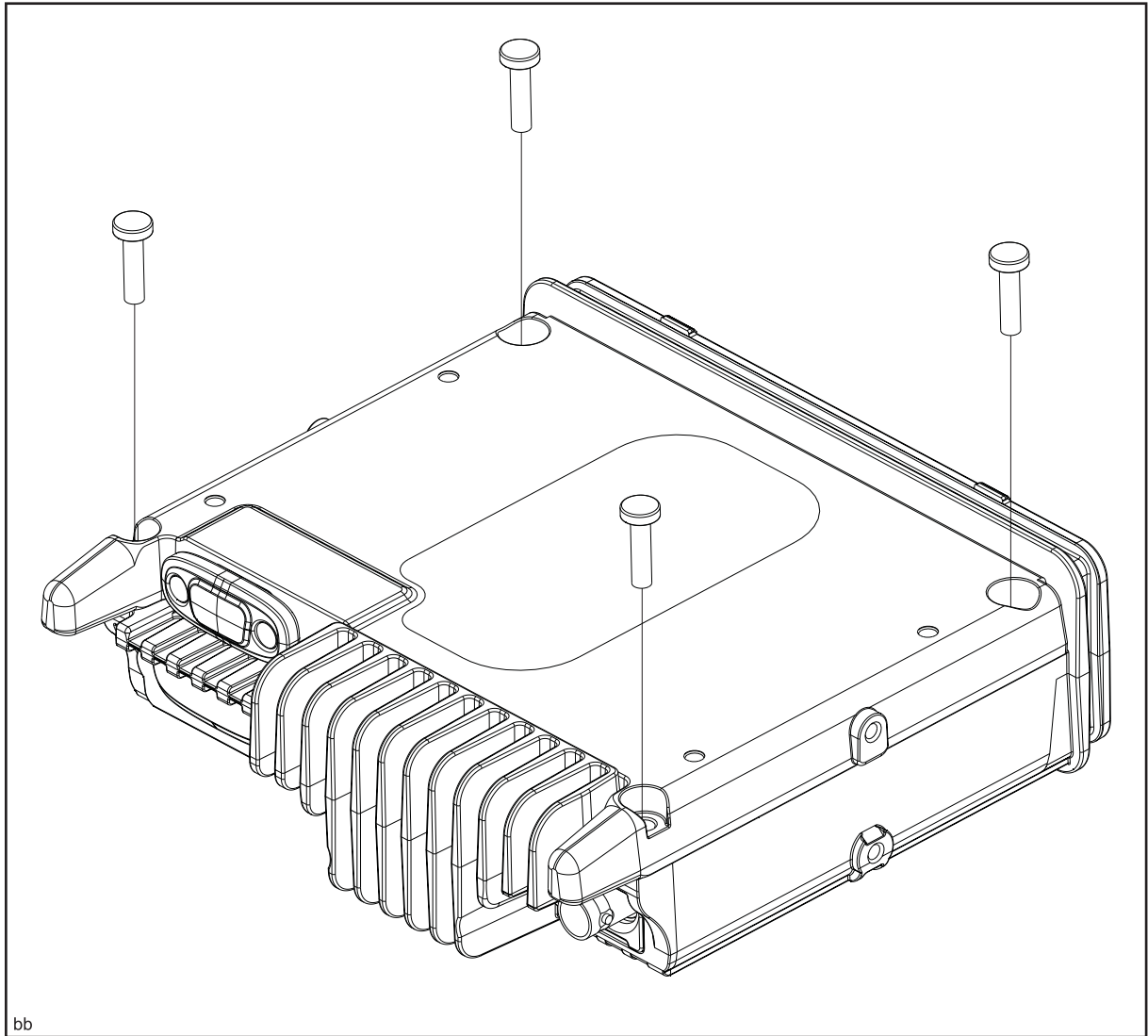

bb

Figure 3.6 The four screws that secure the lid to the chassis of the radio body

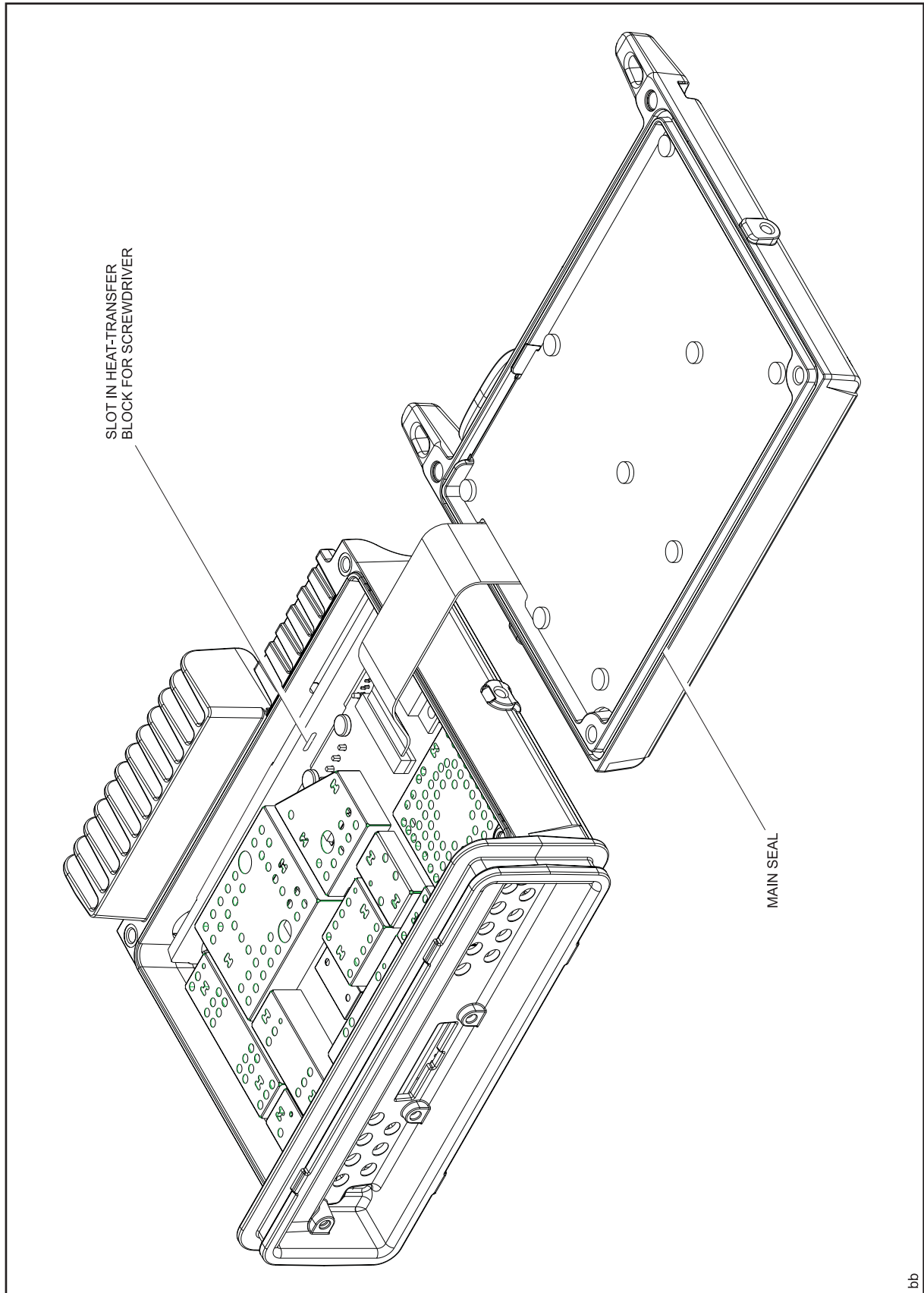

Figure 3.7 Illustration of the lid removed from the chassis of the radio body, with an options board installed in the lid

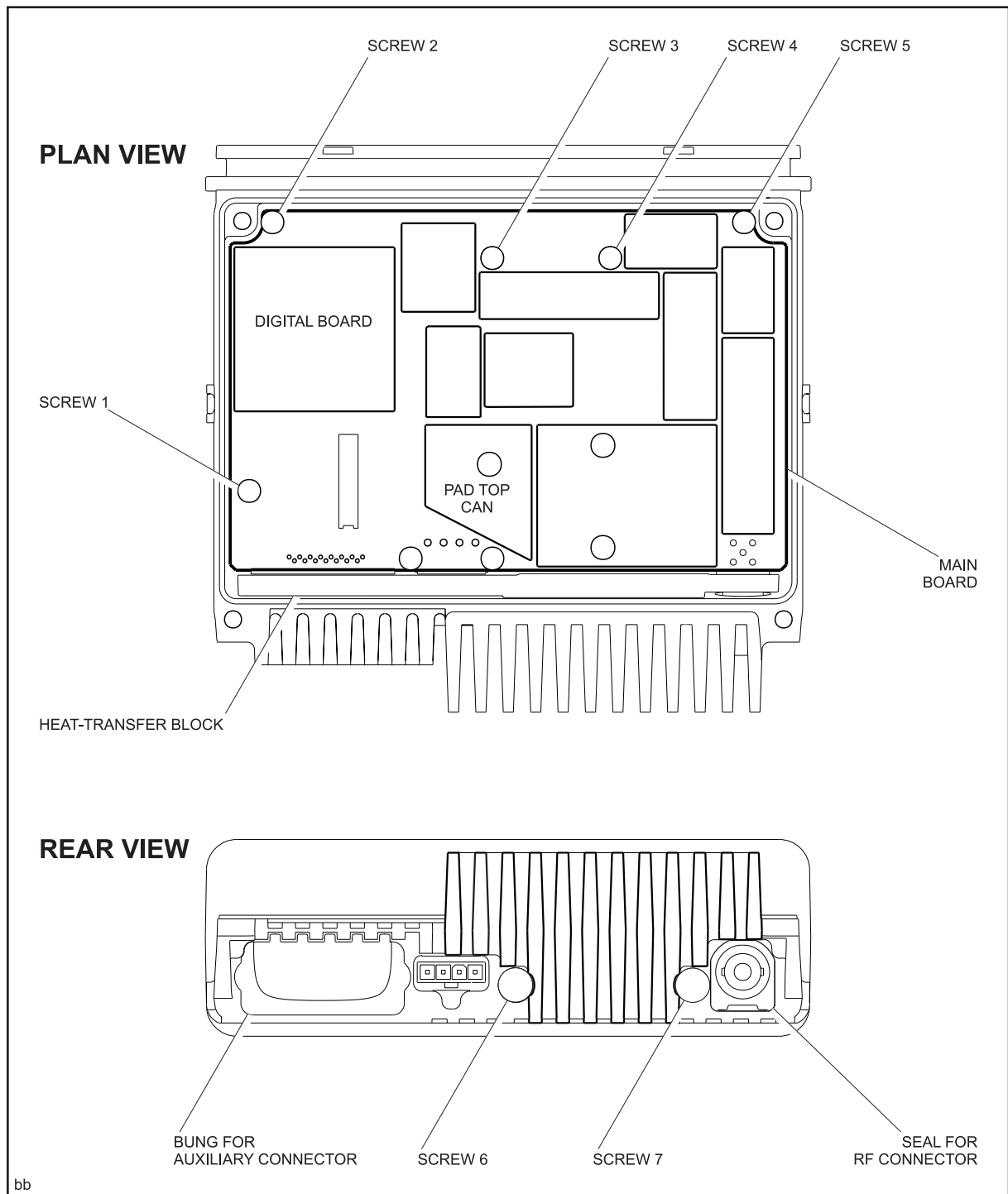

Figure 3.8 Illustration of the chassis showing the screws that secure the main-board assembly

Remove main-board assembly

The second stage in disassembling the radio body is to remove the main-board assembly.

1. Remove the bung (if fitted) covering the auxiliary connector.
2. Remove the rubber seal around the RF connector — preferably by hand. If necessary, however, lever up the seal by inserting the blade of a small (about 3 mm) flat-bladed screwdriver in the gap beneath the seal. See Figure 3.8. Do not damage the seal with the screwdriver.
3. Note the five interior screws securing the main-board assembly; these are labelled screw 1 to screw 5 in Figure 3.8. Use a Torx T10 screwdriver to remove the screws. The order of removal is immaterial, but good practice would be to follow the order from screw 1 to screw 5.
4. Note the two exterior screws securing the main-board assembly; these are labelled screw 6 and screw 7 in Figure 3.8. Use a Torx T20 screwdriver to remove the screws.
5. The main-board assembly is now free of the chassis. Note the slot in the heat-transfer block shown in Figure 3.7. Insert the blade of a small (about 3 to 5 mm) flat-bladed screwdriver in the slot. Tilt the screwdriver to lever up the front edge of the circuit board. Grip the edge of the board and pull out the assembly, but avoid the thermal paste on the heat-transfer block. The area coated with thermal paste is shown in Figure 3.9.

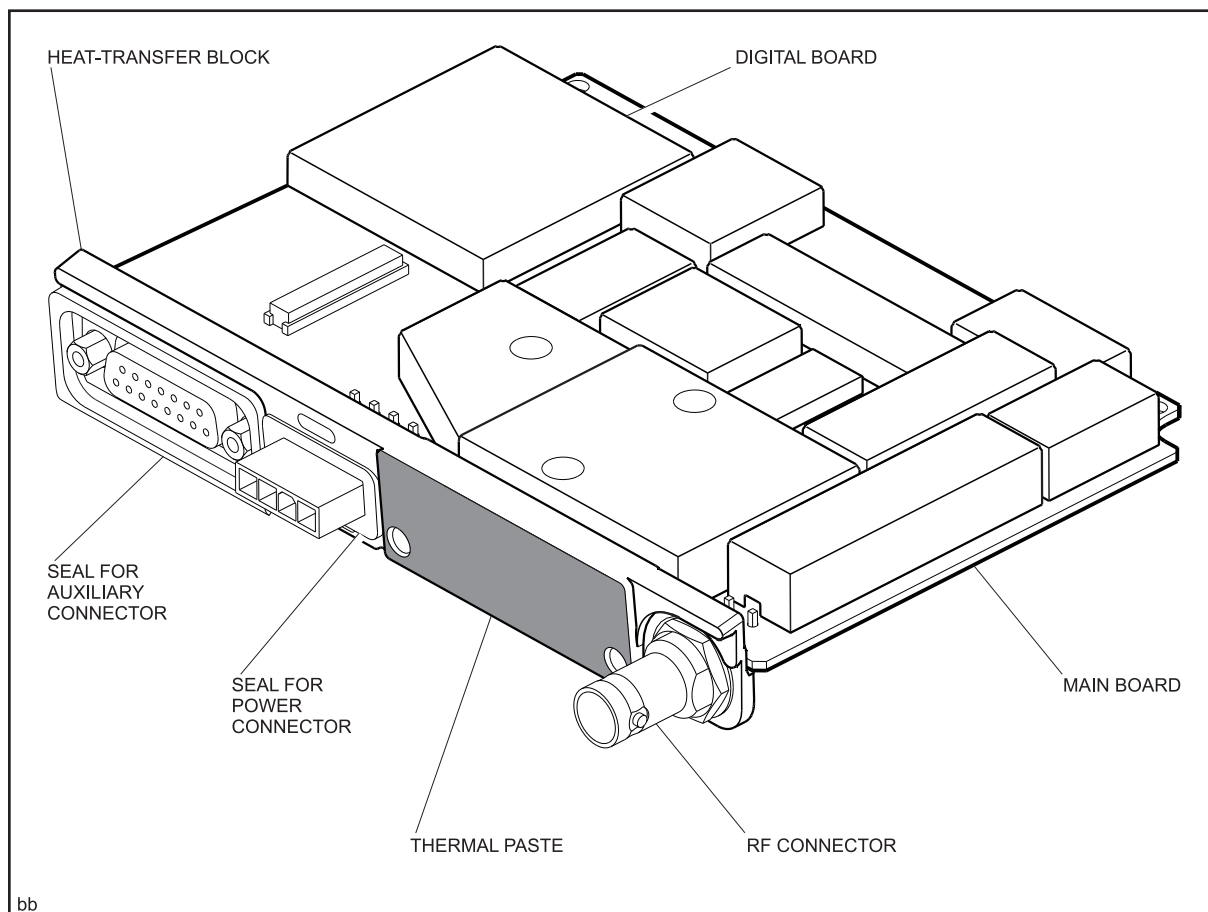

Figure 3.9 The main-board assembly

Table 3.2 Contents of TMAA22-02 Spares kit 2 — mechanical parts of radio body

IPN	Description	Quantity
—	Cover assembly (see below for constituent parts)	1
349-02067- xx	M4 x 16 screw for lid of radio body	4
362-01115- xx	Control-head seal	1
362-01109- xx	Main seal in lid	1
302-50000- xx	Bung for external options connector	1
302-50001- xx	Bung for auxiliary connector	1
362-01113- xx	Seal for RF connector	1
349-02067- xx	External M4 x 16 screw for main-board assembly	2
349-02066- xx	Internal M3 x 10 screw for main-board assembly	5
362-01114- xx	Rubber seal for power connector	1
354-01043- xx	Lock-nut for auxiliary connector	1 pair
362-01112- xx	Outer foam seal for auxiliary connector	1
362-01110- xx	Inner foam seal for auxiliary connector	1
Parts of cover assembly		
303-23166- xx	Cover	1
365-01712- xx	Label for cover	1
Note		
The characters xx in an IPN stand for the issue number. Items in the spares kit will always be the latest issue at the time the spares kit is produced.		

3.4 Re-assembly of Radio Body

Introduction

There are two stages in the re-assembly of the radio body:

- install main-board assembly
- close radio body

The procedures for the two stages are given separately below. The torque values for the screws involved are summarised in Table 3.3.

Install main-board assembly — apply thermal paste

If the main-board assembly needs to be installed, proceed as follows. The first task is to replenish the thermal paste on the heat-transfer block:

1. Thermal paste is required on the area of the heat-transfer block shown in Figure 3.9. This area constitutes the contact area between the main-board assembly and the chassis.
2. Inspect the area on the heat-transfer block requiring thermal paste, as well as the corresponding area on the chassis. If the residual paste has been contaminated with dirt, clean off the paste.
3. Obtain 0.1 cm³ of thermal paste. Use Dow Corning 340 silicone heat-sink compound (IPN 937-00000-55) or the equivalent.
4. Use a stiff brush to apply the paste in a thin film to the required area on the heat-transfer block. Ensure that no bristles from the brush come loose and remain embedded in the paste. The paste needs to be completely free of contaminants.

Table 3.3 Summary of the torque values for the screws used in TM8100 mobile radios

Description of screws	Drive type	Quantity	Torque (N·m)	Torque (lbf·in)
Screws for control-head board	Torx T10	3	0.56	5
Screws for lid of radio body	Torx T20	4	2.5	22
External screws for main-board assembly	Torx T20	2	2.5	22
Internal screws for main-board assembly	Torx T10	5	1.9	17



Important Ensure that the two external screws securing the main-board assembly are properly tightened; otherwise the radio will overheat and might be damaged.

**Install main-board assembly
— secure assembly in chassis**

Complete the installation of the main-board assembly by securing the assembly in the chassis:

1. Place the main-board assembly in position in the chassis.
2. Screw in the two external screws by hand as far as possible. The screws are labelled screw 6 and screw 7 in Figure 3.8. Ensure that the screws start easily and are not cross-threaded.
3. Identify the diagonal edge of the PAD TOP can. The can is shown in Figure 3.8.
4. While pressing down firmly on the diagonal edge of the PAD TOP can, use a Torx T20 torque-driver to tighten the screws to 2.5 N·m (22 lbf·in). (If the screws are not tightened properly, the radio will overheat.) The reason for pressing down on the can is to ensure that the circuit board is seated correctly on the bosses for the five internal screws.
5. Clean off any excess thermal paste on the heat-transfer block.
6. Screw in the five internal screws by hand. The screws are labelled screw 1 to screw 5 in Figure 3.8. Ensure that the screws start easily and are not cross-threaded. Then use a Torx T10 torque-driver to tighten the screws to 1.9 N·m (17 lbf·in).
7. Fit the rubber seal for the RF connector; first fit the upper part of the seal and then press down around the sides of the seal to the bottom. Ensure that the seal is properly seated around its entire periphery.
8. In most radios a bung will have been supplied for the auxiliary connector. In such cases the bung must be fitted again on re-assembly to ensure that the radio is sealed. In fitting the bung, ensure that it is not upside down and that it is properly seated.

Close radio body

Secure the lid and cover of the radio body as follows:

1. If an options board is installed in the lid of the radio body, reconnect the options loom to the internal options connector on the main board. This is best done with the lid placed next to the chassis as shown in Figure 3.7.
2. Place the lid in position on the chassis. Ensure that the main seal in the lid is properly seated.
3. Screw in by hand the four screws that secure the lid. Ensure that the screws start easily and are not cross-threaded. Then use a Torx T20 torque-driver to tighten the screws to 2.5 N·m (22 lbf·in).
4. Fit the cover of the radio body.

3.5 Re-assembly and Attachment of Control Head

Introduction

There are at most three stages in the re-assembly and attachment of the control head. The first two stages concern the two-digit-display control head only, not the blank control head. The three stages are:

- re-assemble mechanical parts of control head
- re-install control-head board
- re-attach control head

The procedures for the three stages are given separately below. The first stage is required only if the control head has been completely disassembled. The second stage is required if the control-head board has been removed; this stage includes the fitting, if applicable, of the circuit board for optional concealed and dynamic microphones. The torque values for the screws involved are included in Table 3.3.

Re-assemble mechanical parts of control head

If the two-digit-display control head has been completely disassembled, re-assemble the mechanical parts as follows:

1. Ensure that the LCD is free of dirt and fingerprints. Wipe the LCD with a soft lens-cleaning cloth. If necessary, clean the LCD using isopropyl alcohol.
2. Place the LCD in its recess in the cover as shown in Figure 3.4. There is only one correct orientation: the small protrusion on the edge of the LCD must be adjacent to the wall of the front panel.
3. Place the keypad in position on the floor of the front panel.
4. Place the speaker in position and, if included, the concealed microphone.
5. Place the space-frame in position. Ensure that the leads from the speaker and, if fitted, the concealed microphone do not foul the frame. The leads will need to be connected to the top of the control-head board when the board is installed.
6. Press down on the space-frame until all six clips on the frame snap into place in their recesses.
7. Ensure that the conductors along the edges of the two elastomeric strips are clean. Wipe the strips with a soft lens-cleaning cloth. If necessary, clean the strips using isopropyl alcohol.
8. Insert the two elastomeric strips in their slots in the space-frame.

Re-install control-head board

Re-install the control-head board and, if included, the optional microphone board as follows. The torque values for the screws securing the control-head board are included in Table 3.3.

1. Place the control-head board in position on the space-frame. Ensure that the board fits inside the four guides on the frame. The guides are labelled guide 1 to guide 4 in Figure 3.3.
2. Press straight down on the control-head board until the three clips on the space-frame snap into position against the board. The clips are labelled clip 1 to clip 3 in Figure 3.3. It is important **not** to press down on the circuit board at an angle. To do so might distort the elastomeric strips, causing failure in the operation of the LCD.
3. Screw in by hand the three screws that secure the control-head board. The screws are labelled screw 1 to screw 3 in Figure 3.3. Ensure that the screws start easily and are not cross-threaded. Then, beginning with screw 1, use a Torx T10 torque-driver to tighten the screws to 0.6 N·m (5 lbf·in).
4. If an optional microphone board is included, attach the board to the control-head board. The two sockets on the former connect to corresponding plugs on the latter.
5. If a concealed microphone is fitted, solder the leads from the microphone to the relevant pads on the control-head board. The pads are shown in Figure 3.3.
6. If the speaker leads were originally connected to the control-head board, as noted in Subsection 3.2, then reconnect the leads. Orient the plug on the leads so that the ridge on one side of the plug is uppermost.
7. Push the knob onto the shaft of the volume-control potentiometer. Ensure that the knob turns freely.

Re-attach control head

Re-attach the control head to the radio body as follows. The procedure applies to both the two-digit-display control head and the blank control head.

1. Orient the control head with respect to the radio body as noted in Subsection 3.1.
2. Reconnect the control-head loom to the connector on the radio body. Refer to Figure 3.2.
3. Align the control head with the inner face of the radio body. Ensure that the control-head loom folds properly into the space between the control head and the radio body.
4. Press the control head against the radio body until it clips into position. Ensure that the seal is not damaged in the process.
5. Continue with the servicing procedure.